



FILTRATION AND TREATMENT SYSTEMS CATALOG



**PRODUCTS FOR COMMERCIAL
APPLICATIONS BY
BLAKE WATER SOLUTIONS**





THE BLAKE GROUP

4 New Park Road, East Windsor, CT 06088

PHONE: (860) 243-1491 FAX: (860) 528-8057

E-MAIL: bwsinfo@blakeequip.com

About Us

The Blake Group's corporate offices and manufacturing facilities are located in East Windsor, Connecticut. In 1967, Blake entered into the water well and water treatment business, and through strategic acquisitions and organic growth, we have become the largest wholesale distributor of water well and contractor products in the Northeast.

In 2006, The Blake Group purchased the residential/light commercial division of Tenery Christ Water of New Britain, Connecticut. This acquisition not only added technical and manufacturing expertise, but it also added to the group's product offerings.

With 20 offices, a 50,000 square foot central distribution facility, and our own private fleet of delivery vehicles, Blake has the product that you want, when you want it.

As an active member of the WQA, a non-profit trade association, we take pride that all of our managers and sales force are CWS and CSR certified. You can always rely on Blake for sound advice and technically proficient analysis for all your water treatment conditions.

See the back cover of this catalog for the location near you.

TABLE OF CONTENTS

COMMERCIAL WATER SOFTENERS

Professional Series Single Tank Softeners with Brine Tank

1" Fleck 2750 Control Valve – 1 thru 7 Cubic foot Softeners.....	2-3
1-1/2" Fleck 2850s Control Valve – 2 thru 20 Cubic foot Softeners.....	4-5
2" Fleck 2900s Control Valve – 3 thru 20 Cubic foot Softeners.....	6-7
2" Fleck 3150 Control Valve – 10 thru 40 Cubic foot Softeners.....	8-9
3" Fleck 3900 Control Valve – 10 thru 40 Cubic foot Softeners.....	10-11

Professional Series Twin Alternating Softeners with Brine Tank

1" Fleck 9000 Control Valve – 1 thru 7 Cubic foot Softeners.....	12-13
1-1/2" Fleck 9500 Control Valve – 2 thru 20 Cubic foot Softeners.....	14-15
2" Fleck 2900s Control Valve – 3 thru 20 Cubic foot Softeners.....	16-17
3" Fleck 3900 Control Valve – 10 thru 40 Cubic foot Softeners.....	18-19

COMMERCIAL WATER FILTERS

Professional Series Filters Less Filter Media

1" Fleck 2750 Control Valve – 1 thru 6 Cubic foot Filters.....	20-21
1-1/2" Fleck 2850s Control Valve – 2 thru 10 Cubic Filters.....	22-23
2" Fleck 3150 Control Valve – 6 thru 26 Cubic foot Filters.....	24-25
3" Fleck 3900 Control Valve – 8 thru 26 Cubic foot Filters.....	26-27

FILTRATION MEDIA

Filtration and Selective Media Part Number Listing.....	28
---	----

Multi-Media Application Listing.....	29
--------------------------------------	----

Selective Media Data

Media for Sediment – Turbidity – Suspended Solids Removal

Filter Ag	30
Chemsorb.....	31

Iron – Hydrogen Sulfide – Manganese Removal

Birm.....	32
Catalox.....	33
Greensand Plus.....	34

Carbon Filtration

Taste & Odor Removal.....	35
Iron & Hydrogen Sulfide	36
VOC – TTHM – Organics	37

COMMERCIAL SOFTENING SYSTEMS

BWS PROFESSIONAL SERIES

PIPE SIZE 1"
CONTROL VALVE 2750
POLY LINED FRP TANK
3/4" PIPE (1.05" OD) DISTRIBUTOR

Commercial Water Softeners described here are suitable for applications ranging from 20,000 to 210,000 grains of hardness removal capacity at flow rates of 10 to 32 gpm depending on the system selected. Installations might include restaurants, car washes, laundromats, small boilers, and other commercial applications.

Control Valve

The 2750 sequence control valve operates on commands from the valve controller. A hydraulically balanced piston glides effortlessly along noncorrosive spacers and seals to a precise position to provide controlled backwash, brine draw/slow rinse, fast rinse and brine refill as well as the service cycle. The precision motor-driven valve performs in the toughest applications and is made of high quality lead-free brass for a long and reliable life.

Standard Control Valve Features:

- Electromechanical or electronic controller
- Time clock or demand initiated regeneration
- Lead-free brass constructed valve
- Environmental NEMA 3R valve cover
- 1" male pipe threaded inlet and outlet connection
- 3/4" male pipe threaded drain connection
- 3/4" pipe (1.05" OD) distributor
- Working pressure range 20 – 125psi
- Working temperature range 34-110°F
- Valve Cv 18gpm @1psi pressure drop

Controller

Electromechanical 7 or 12 day timers operate on 120v and initiate the regeneration cycle at 2AM on the selected days. Days are selected by extending the lever on the day's wheel. 7 day timers are used for specific single day weekly regeneration; 12 day timers offer flexible regeneration frequency from daily to 6, 4, 3, or 2 day intervals. The duration of the cycles is adjusted by positioning pins on the timer wheel. Metered units regenerate at 2AM after the pre-set volume of water has been softened. Volume is set on the meter dial and is calculated on unit capacity and water hardness.

Electronic programmable 24v microprocessor controller offers complete flexibility for setting regeneration time, frequency, and cycle duration (combined time up to 16 hours). The commercial NXT controller has a full text, two-line sixteen character LCD backlit display. Meter or Remote signal (immediate or delayed) or controller initiated regeneration selectable. Remote lockout input and a 3amp fused programmable auxiliary Dry Contact Relay provided for system pump start/stop. Programmed operating parameters are stored in permanent memory and time of day is maintained during power outages (12 hours). Operation history is stored in memory for system diagnostics and troubleshooting.

Softening Resin

The ion exchange media is a high quality, strong acid softener (Cation) resin in the sodium (Na) form with a very high whole bead count and no color throw. It is physically hard and chlorine resistant. The resin combines high operating capacity with excellent chemical and physical stability for long dependable life. Request resin specifications for details.

Resin Tank

All SC series Softeners feature noncorrosive fiberglass tanks with a one-piece thermoplastic inner liner. The tanks have a maximum working pressure rating of 150psi and a working temperature of 120°F. The tanks are NSF/ANSI Standard 61 rated and meet FDA requirements.

Brine Tank

The brine tank is a combination brine maker and salt storage vessel. It is constructed of tough, high density polyethylene and features a grid platform for maximum saturation of brine.

Brine System

Brine refill is automatically controlled by the timer/controller to provide the correct amount of brine for each regeneration. The refill system is complete with an air check valve, brine safety float assembly, and safety shut-off valve, all housed in a brine well providing dependable, accurate regenerations.



SERIES OPTIONS:

1. No hard water bypass piston
2. Separate source backwash/rinse
3. Hot water service (time clock 180° meter 150°)
4. Auxiliary switch for system signal
5. Service valve operator
5. NXT electronic multi-tank systems (up to 4 tanks)

COMMERCIAL SOFTENING SYSTEMS

BWS PROFESSIONAL SERIES

PIPE SIZE 1"
CONTROL VALVE 2750
POLY LINED FRP TANK
3/4" PIPE (1.05" OD) DISTRIBUTOR

SIZING AND DIMENSION GUIDE

Series	Mineral Tank		Under Bed 1/4 x 1/8 .#20	Brine Tank		Softening Capacity ¹		lbs. Salt Per Regeneration ²		Flow GPM C/P	Pressure Drop PSI C/P	BKW GPM	
	Tank Size ⁴	Resin cu. ft		Size ^{4,5}	Salt Fill	Max	Min ³	Max	Min				
A30F27	9 x 48	1	-	10	18 x 40	400	30K	20K	15	6	10/11	15/25	2
A45F27	10 x 54	1.5	-	15	18 x 40	400	45K	30K	22.5	9	10/14	15/25	2.4
A60F27	12 x 52	2	-	30	24 x 41	600	60K	40K	30	12	10/20	15/25	4
A75F27	13 x 54	2.5	-	30	24 x 41	600	75K	50K	38	15	12/24	15/25	5
A90F27	14 x 65	3	-	60	24 x 41	600	90K	60K	45	18	18/30	15/25	5
A105F27	16 x 65	3.5	-	50	24 x 41	600	105K	70K	53	21	19/31	15/25	7
A120F27	16 x 65	4	-	80	24 x 41	600	120K	80K	60	24	19/31	15/25	7
A150F27	21 x 62	5	-	100	24 x 50	800	150K	100K	75	30	20/32	15/25	12
A180F27	21 x 62	6	-	100	24 x 50	800	180K	120K	90	36	20/32	15/25	12
A210F27	21 x 62	7	-	100	24 x 50	800	210K	140K	105	42	20/32	15/25	12

C=Continuous P=Peak

ORDERING SELECTION GUIDE

Series	TIME CLOCK		METERED			Space Required W x L x H	Shipping Weight (lbs.)
	12-DAY PART #	ELECTRIC PART #	STANDARD RANGE* PART #	EXTENDED RANGE** PART #	XT*** ELECTRONIC PART #		
A30F27	SC1T30	SC1TE30	SC1M30	SC1MX30	SC1ME30	18" x 32" x 59"	110
A45F27	SC1T45	SC1TE45	SC1M45	SC1MX45	SC1ME45	18" x 33" x 65"	150
A60F27	SC1T60	SC1TE60	SC1M60	SC1MX60	SC1ME60	26" x 40" x 68"	190
A75F27	SC1T75	SC1TE75	SC1M75	SC1MX75	SC1ME75	26" x 44" x 81"	240
A90F27	SC1T90	SC1TE90	SC1M90	SC1MX90	SC1ME90	26" x 44" x 81"	265
A105F27	SC1T105	SC1TE105	SC1M105	SC1MX105	SC1ME105	26" x 48" x 81"	390
A120F27	SC1T120	SC1TE120	SC1M120	SC1MX120	SC1ME120	26" x 48" x 81"	320
A150F27	SC1T150	SC1TE150	SC1M150	SC1MX150	SC1ME150	26" x 51" x 78"	380
A180F27	SC1T180	SC1TE180	SC1M180	SC1MX180	SC1ME180	26" x 51" x 78"	410
A210F27	SC1T210	SC1TE210	SC1M210	SC1MX210	SC1ME210	26" x 51" x 78"	450

For 7-Day Timer option, add 7D to the item part number as shown here:

SC1T60 to SC1T7D60.

For No Hard Water Bypass Piston Option (NHWBP), add N to the item part number as shown here: SC1T7DN60

For System 5, 6, 9, or 14, add S5, S6, S9, or S14 to the end of the item number as shown here: SC1ME60S6. Note: Only ME units are available in S5, S6, S9, or S14 configurations.

See page 47 for details.

KEY TO THE NOTATIONS ABOVE:

1. Capacities are based on resin manufacturers' data and are dependant upon influent water TDS, temperature, bed depth, pressure, and flow rates. The raw water is to be free of oil, color and turbidity.
2. All units from BWS are set at minimum salt settings.
3. Use the minimum capacity when sizing units.
4. Pipe sizes, tank sizes, and space requirements are in inches.

Meter Ranges:

- * 1" Meter: Standard Range = 5,270 gallons
- ** 1" Meter: Extended Range = 23,350 gallons
- ***XT Electronic Meter: 9,999,999 gallons

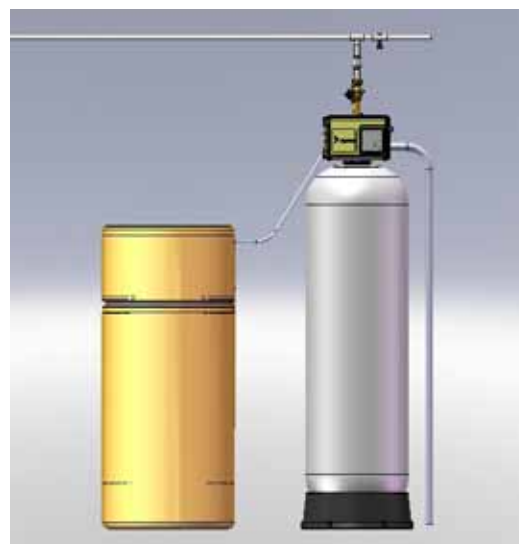

COMMERCIAL SOFTENING SYSTEMS

BWS PROFESSIONAL SERIES

PIPE SIZE 1.5"
CONTROL VALVE 2850S
POLY LINED FRP TANK
1.5" PIPE (1.90" OD) DISTRIBUTOR

Commercial Water Softeners described here are suitable for applications ranging from 40,000 to 600,000 grains of hardness removal capacity at flow rates of 10 to 90 gpm depending on the system selected. Installations might include restaurants, car washes, laundromats, small boilers, and other commercial applications.

Control Valve

The 2850S sequence control valve operates on commands from the valve controller. A hydraulically balanced piston glides effortlessly along noncorrosive spacers and seals to a precise position to provide controlled backwash, brine draw/slow rinse, fast rinse and brine refill as well as the service cycle. The precision motor-driven valve performs in the toughest applications and is made of high quality lead free brass for a long and reliable life.

Standard Control Valve Features:

- Electromechanical or electronic controller
- Time clock or demand initiated regeneration
- Lead-free brass constructed valve
- Environmental NEMA 3R valve cover
- 1-1/2" female pipe threaded inlet and outlet connection
- 1-1/4" female pipe threaded drain connection
- 1.5" pipe (1.90" OD) distributor
- Working pressure range 20 – 125psi
- Working temperature range 34-110°F
- Valve Cv 18gpm @1psi pressure drop

Controller

Electromechanical 7 or 12 day timers operate on 120v and initiate the regeneration cycle at 2AM on the selected days. Days are selected by extending the lever on the day's wheel. 7 day timers are used for specific single day weekly regeneration; 12 day timers offer flexible regeneration frequency from daily to 6, 4, 3, or 2 day intervals. The duration of the cycles is adjusted by positioning pins on the timer wheel. Metered units regenerate at 2AM after the pre-set volume of water has been softened. Volume is set on the meter dial and is calculated on unit capacity and water hardness.

Electronic programmable 24v microprocessor controller offers complete flexibility for setting regeneration time, frequency, and cycle duration (combined time up to 16 hours). The commercial NXT controller has a full text, two-line sixteen character LCD backlit display. Meter or Remote signal (immediate or delayed) or controller initiated regeneration selectable. Remote lockout input and a 3amp fused programmable auxiliary Dry Contact Relay provided for system pump start/stop. Programmed operating parameters are stored in permanent memory and time of day is maintained during power outages (12 hours). Operation history is stored in memory for system diagnostics and troubleshooting.

Softening Resin

The ion exchange media is a high quality, strong acid softener (Cation) resin in the sodium (Na) form with a very high whole bead count and no color throw. It is physically hard and chlorine resistant. The resin combines high operating capacity with excellent chemical and physical stability for long dependable life. Request resin specifications for details.

Resin Tank

All SC series Softeners feature noncorrosive fiberglass tanks with a one-piece thermoplastic inner liner. The tanks have a maximum working pressure rating of 150psi and a working temperature of 120°F. The tanks are NSF/ANSI Standard 61 rated and meet FDA requirements.

Brine Tank

The brine tank is a combination brine maker and salt storage vessel. It is constructed of tough, high density polyethylene and features a grid platform for maximum saturation of brine. (30" diameter and larger are not supplied with a grid.)

Brine System

Brine refill is automatically controlled by the timer/controller to provide the correct amount of brine for each regeneration. The refill system is complete with an air check valve, brine safety float assembly, and safety shut-off valve, all housed in a brine well providing dependable, accurate regenerations.



SERIES OPTIONS:

1. No hard water bypass piston
2. Separate source backwash/rinse
3. Hot water (time clock 180°, meter 150°)
4. Auxilliary switch for system signal
5. Service valve operator
6. NXT electronic multi-tank system (up to 4 tanks)
7. Low flow meter sleeved to 1"

COMMERCIAL SOFTENING SYSTEMS

BWS PROFESSIONAL SERIES

PIPE SIZE 1.5"
CONTROL VALVE 2850S
POLY LINED FRP TANK
1.5" PIPE (1.90" OD) DISTRIBUTOR

SIZING AND DIMENSION GUIDE

Series	Mineral Tank		Under Bed		Brine Tank		Softening Capacity ¹		lbs. Salt Per Regeneration ²		Flow GPM C/P	Pressure Drop PSI C/P	BKW GPM
	Tank Size ⁴	Resin cu. ft	1/4 x 1/8	.#20	Size ^{4,5}	Salt Fill	Max	Min ³	Max	Min			
A60F28	12 x 52	2		30	24 x 41	600	60K	40K	30	12	10/20	15/25	4
A75F28	13 x 54	2.5		30	24 x 41	600	75K	50K	38	15	12/24	15/25	5
A90F28	14 x 65	3		60	24 x 41	600	90K	60K	45	18	15/30	15/25	5
A105F28	16 x 65	3.5		50	24 x 41	600	105K	70K	53	21	27/55	15/25	7
A120F28	16 x 65	4		80	24 x 41	600	120K	80K	60	24	27/55	15/25	7
A150F28	21 x 62	5		100	24 x 50	800	150K	100K	75	30	34/66	15/25	12
A180F28	21 x 62	6		100	24 x 50	800	180K	120K	90	36	40/66	15/25	12
A210F28	21 x 62	7		100	24 x 50	800	210K	140K	105	42	46/67	15/25	12
A240F28	24 x 72	8	100	100	30 x 48	1200	240K	160K	120	48	50/67	15/25	15
A270F28	24 x 72	9	100	100	39 x 48	2000	270K	180K	135	54	50/67	15/25	15
A300F28	24 x 72	10	100	100	39 x 48	2000	300K	200K	150	60	50/67	15/25	15
A450F28	30 x 72	15	150	150	39 x 48	2000	450K	300K	225	90	70/90	15/25	25
A600F28	36 x 72	20	250	250	39 x 48	2000	600K	400K	300	120	70/90	15/25	35

C=Continuous P=Peak

ORDERING SELECTION GUIDE

Series	TIME CLOCK		METERED			Space Required W x L x H	Shipping Weight (lbs.)
	12-DAY PART #	ELECTRIC PART #	STANDARD RANGE* PART #	EXTENDED RANGE** PART #	XT*** ELECTRONIC PART #		
A60F28	SC2T60	SC2TE60	SC2M60	SC2MX60	SC2ME60	26" x 40" x 68"	210
A75F28	SC2T75	SC2TE75	SC2M75	SC2MX75	SC2ME75	26" x 44" x 81"	240
A90F28	SC2T90	SC2TE90	SC2M90	SC2MX90	SC2ME90	26" x 44" x 81"	265
A105F28	SC2T105	SC2TE105	SC2M105	SC2MX105	SC2ME105	26" x 48" x 81"	290
A120F28	SC2T120	SC2TE120	SC2M120	SC2MX120	SC2ME120	26" x 48" x 81"	320
A150F28	SC2T150	SC2TE150	SC2M150	SC2MX150	SC2ME150	26" x 51" x 78"	380
A180F28	SC2T180	SC2TE180	SC2M180	SC2MX180	SC2ME180	26" x 51" x 78"	410
A210F28	SC2T210	SC2TE210	SC2M210	SC2MX210	SC2ME210	26" x 51" x 78"	450
A240F28	SC2T240	SC2TE240	SC2M240	SC2MX240	SC2ME240	32" x 58" x 88"	660
A270F28	SC2T270	SC2TE270	SC2M270	SC2MX270	SC2ME270	41" x 72" x 88"	685
A300F28	SC2T300	SC2TE300	SC2M300	SC2MX300	SC2ME300	41" x 72" x 88"	710
A450F28	SC2T450	SC2TE450	SC2M450	SC2MX450	SC2ME450	41" x 82" x 108"	1200
A600F28	SC2T600	SC2TE600	SC2M600	SC2MX600	SC2ME600	41" x 88" x 108"	1500

For 7-Day Timer option, add 7D to the item part number as shown here: SC2T60 to SC2T7D60.

For No Hard Water Bypass Piston Option (NHWBP), add N to the item part number as shown here: SC2T7DN60

For System 5, 6, 9, or 14, add S5, S6, S9, or S14 to the end of the item number as shown here: SC1ME60S6. Note: Only ME units are available in S5, S6, S9, or S14 configurations. See page 47 for details.

Meter Ranges:

* 1-1/2" Meter: Standard Range = 10,625 gallons

** 1-1/2" Meter: Extended Range = 53,125 gallons

***XT Electronic Meter: 9,999,999 gallons

KEY TO THE NOTATIONS ABOVE:

1. Capacities are based on resin manufacturers' data and are dependant upon influent water TDS, temperature, bed depth, pressure, and flow rates. The raw water is to be free of oil, color and turbidity.
2. All units from BWS are set at minimum salt settings.
3. Use the minimum capacity when sizing units.
4. Pipe sizes, tank sizes, and space requirements are in inches.
5. 30" and larger brine tanks have no grid plate

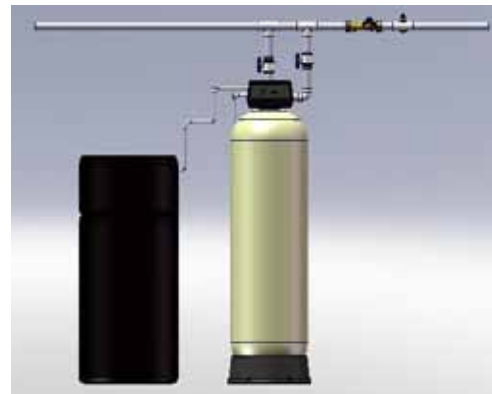

COMMERCIAL SOFTENING SYSTEMS

BWS PROFESSIONAL SERIES

PIPE SIZE 2"
CONTROL VALVE 2900S
POLY LINED FRP TANK
1.5" PIPE (1.90" OD) DISTRIBUTOR

Commercial Water Softeners described here are suitable for applications ranging from 60,000 to 600,000 grains of hardness removal capacity at flow rates of 15 to 105 gpm depending on the system selected. Installations might include restaurants, car washes, laundromats, small boilers, and other commercial applications.

Control Valve

The 2900S sequence control valve operates on commands from the valve controller. A hydraulically balanced piston glides effortlessly along noncorrosive spacers and seals to a precise position to provide controlled backwash, brine draw/slow rinse, fast rinse and brine refill as well as the service cycle. The precision motor-driven valve performs in the toughest applications and is made of high quality lead-free brass for a long and reliable life.

Standard Control Valve Features:

- Electromechanical or electronic controller
- Time clock or demand initiated regeneration
- Lead-free brass constructed valve
- Environmental NEMA 3R valve cover
- 2" female pipe threaded inlet and outlet connection
- 1" male pipe threaded drain connection
- 3/4" pipe (1.05" OD) distributor
- Working pressure range 20 – 125psi
- Working temperature range 34-110°F
- Valve Cv 18gpm @1psi pressure drop

Controller

Electromechanical 7 or 12 day timers operate on 120v and initiate the regeneration cycle at 2AM on the selected days. Days are selected by extending the lever on the day's wheel. 7 day timers are used for specific single day weekly regeneration; 12 day timers offer flexible regeneration frequency from daily to 6, 4, 3, or 2 day intervals. The duration of the cycles is adjusted by positioning pins on the timer wheel. Metered units regenerate at 2AM after the pre-set volume of water has been softened. Volume is set on the meter dial and is calculated on unit capacity and water hardness.



Electronic programmable 24v microprocessor controller offers complete flexibility for setting regeneration time, frequency, and cycle duration (combined time up to 16 hours). The commercial NXT controller has a full text, two-line sixteen character LCD backlit display. Meter or Remote signal (immediate or delayed) or controller initiated regeneration selectable. Remote lockout input and a 3amp fused programmable auxiliary Dry Contact Relay provided for system pump start/stop. Programmed operating parameters are stored in permanent memory and time of day is maintained during power outages (12 hours). Operation history is stored in memory for system diagnostics and troubleshooting.

Softening Resin

The ion exchange media is a high quality, strong acid softener (Cation) resin in the sodium (Na) form with a very high whole bead count and no color throw. It is physically hard and chlorine resistant. The resin combines high operating capacity with excellent chemical and physical stability for long dependable life. Request resin specifications for details.

Resin Tank

All SC series Softeners feature noncorrosive fiberglass tanks with a one-piece thermoplastic inner liner. The tanks have a maximum working pressure rating of 150psi and a working temperature of 120°F. The tanks are NSF/ANSI Standard 61 rated and meet FDA requirements.

Brine Tank

The brine tank is a combination brine maker and salt storage vessel. It is constructed of tough, high density polyethylene and features a grid platform for maximum saturation of brine. (30" diameter and larger are not supplied with a grid.)

Brine System

Brine tank refill is automatically controlled by the timer/controller to provide the correct amount of brine for each regeneration. The refill system is complete with an air check valve, brine safety float assembly, and safety shut-off valve, all housed in a brine well providing dependable, accurate regenerations.

SERIES OPTIONS:

1. No hard water bypass piston
2. Separate source backwash/rinse
3. Microswitch for lockout signal (electromechanical systems)
4. Service valve operator
5. NXT electronic multi-tank systems (up to 4 tanks)

COMMERCIAL SOFTENING SYSTEMS

BWS PROFESSIONAL SERIES

PIPE SIZE 2"
CONTROL VALVE 2900S
POLY LINED FRP TANK
1.5" PIPE (1.90" OD) DISTRIBUTOR

SIZING AND DIMENSION GUIDE

Series	Mineral Tank		Under Bed 1/4 x 1/8 .#20	Brine Tank		Softening Capacity ¹		lbs. Salt Per Regeneration ²		Flow GPM C/P	Pressure Drop PSI C/P	BKW GPM
	Tank Size ⁴	Resin cu. ft		Size ^{4,5}	Salt Fill	Max	Min ³	Max	Min			
A90F29	14 x 65	3	40	24 x 41	600	90K	60K	45	18	15/25	15/25	5
A120F29	16 x 65	4	50	24 x 41	600	120K	80K	60	24	20/35	15/25	7
A150F29	21 x 62	5	100	24 x 50	800	150K	100K	75	30	25/40	15/25	12
A180F29	21 x 62	6	100	24 x 50	800	180K	120K	90	36	30/48	15/25	12
A210F29	21 x 62	7	100	24 x 50	800	210K	140K	105	42	35/56	15/25	12
A240F29	24 x 72	8	100	30 x 48	1200	240K	160K	120	48	45/64	15/25	15
A300F29	24 x 72	10	100	39 x 48	2000	300K	200K	150	60	55/80	15/25	15
A450F29	30 x 72	15	150	39 x 48	2000	450K	300K	225	90	75/105	15/25	25
A600F29	36 x 72	20	250	39 x 48	2000	600K	400K	300	120	85/105	15/25	35

C=Continuous P=Peak

ORDERING SELECTION GUIDE

Series	TIME CLOCK		METERED				Space Required W x L x H	Shipping Weight (lbs.)
	12-DAY PART #	ELECTRIC PART #	STANDARD RANGE* PART #	EXTENDED RANGE** PART #	XT*** ELECTRONIC PART #			
A90F29	SC3T90	SC3TE90	SC3M90	SC3MX90	SC3ME90	26" x 44" x 81"	350	
A120F29	SC3T120	SC3TE120	SC3M120	SC3MX120	SC3ME120	26" x 46" x 81"	410	
A150F29	SC3T150	SC3TE150	SC3M150	SC3MX150	SC3ME150	26" x 51" x 78"	475	
A180F29	SC3T180	SC3TE180	SC3M180	SC3MX180	SC3ME180	26" x 51" x 78"	525	
A210F29	SC3T210	SC3TE210	SC3M210	SC3MX210	SC3ME210	26" x 51" x 78"	575	
A240F29	SC3T240	SC3TE240	SC3M240	SC3MX240	SC3ME240	32" x 60" x 88"	910	
A300F29	SC3T300	SC3TE300	SC3M300	SC3MX300	SC3ME300	41" x 69" x 88"	1010	
A450F29	SC3T450	SC3TE450	SC3M450	SC3MX450	SC3ME450	41" x 75" x 88"	1460	
A600F29	SC3T600	SC3TE600	SC3M600	SC3MX600	SC3ME600	41" x 81" x 88"	2010	

For 7-Day Timer option, add 7D to the item part number as shown here: SC3T60 to SC3T7D60.

For No Hard Water Bypass Piston Option (NHWPB), add N to the item part number as shown here: SC3T7DN60

For System 5, 6, 9, or 14, add S5, S6, S9, or S14 to the end of the item number as shown here: SC3ME60S6. Note: Only ME units are available in S5, S6, S9, or S14 configurations.

See page 47 for details.

KEY TO THE NOTATIONS ABOVE:

1. Capacities are based on resin manufacturers' data and are dependant upon influent water TDS, temperature, bed depth, pressure, and flow rates. The raw water is to be free of oil, color and turbidity.
2. All units from BWS are set at minimum salt settings.
3. Use the minimum capacity when sizing units.
4. Pipe sizes, tank sizes, and space requirements are in inches.
5. 30" and larger brine tanks have no grid plate.

Meter Ranges:

- * 2" Meter: Standard Range = 21,250 gallons
- ** 2" Meter: Extended Range = 106,250 gallons
- ***XT Electronic Meter: 9,999,999 gallons



COMMERCIAL SOFTENING SYSTEMS

BWS PROFESSIONAL SERIES

PIPE SIZE 2"
CONTROL VALVE 3150
POLY LINED FRP TANK
2" PIPE (2.375" OD) DISTRIBUTOR

Commercial Water Softeners described here are suitable for applications ranging from 200,000 to 1,200,000 grains of hardness removal capacity at flow rates of 50 to 103 gpm depending on the system selected. Installations might include restaurants, car washes, laundromats, small boilers, and other light commercial applications.

Control Valve

The 3150 sequence control valve operates on commands from the valve controller. A hydraulically balanced piston glides effortlessly along noncorrosive spacers and seals to a precise position to provide controlled backwash, brine draw/slow rinse, fast rinse and brine refill as well as the service cycle. The precision motor-driven valve performs in the toughest applications and is made of high quality lead free brass for a long and reliable life.

Standard Control Valve Features:

- Electromechanical or electronic controller
- Time clock or demand initiated regeneration
- Lead-free brass constructed valve
- Environmental NEMA 3R valve cover
- 2" female pipe threaded inlet and outlet connection
- 2" female pipe threaded drain connection
- 1.5" pipe (1.90" OD) distributor
- Working pressure range 20 – 125psi
- Working temperature range 34-110°F
- Valve Cv 24.8gpm @1psi pressure drop

Controller

Electromechanical 7 or 12 day timers operate on 120v and initiate the regeneration cycle at 2AM on the selected days. Days are selected by extending the lever on the day's wheel. 7 day timers are used for specific single day weekly regeneration; 12 day timers offer flexible regeneration frequency from daily to 6, 4, 3, or 2 day intervals. The duration of the cycles is adjusted by positioning pins on the timer wheel. Metered units regenerate at 2AM after the pre-set volume of water has been softened. Volume is set on the meter dial and is calculated on unit capacity and water hardness.

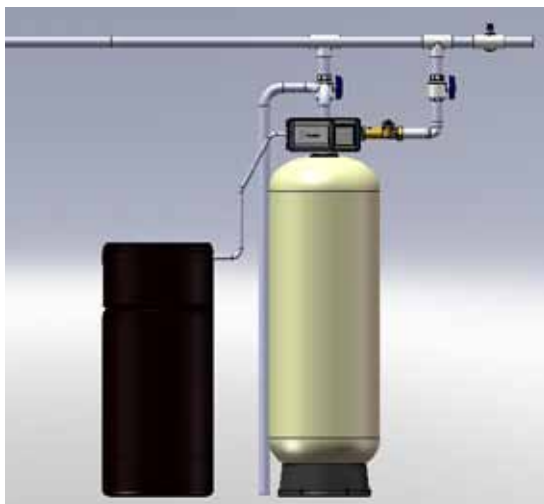

Electronic programmable 24v microprocessor controller offers complete flexibility for setting regeneration time, frequency, and cycle duration (combined time up to 16 hours). The commercial NXT controller has a full text, two-line sixteen character LCD backlit display. Meter or Remote signal (immediate or delayed) or controller initiated regeneration selectable. Remote lockout input and a 3amp fused programmable auxiliary Dry Contact Relay provided for system pump start/stop. Programmed operating parameters are stored in permanent memory and time of day is maintained during power outages (12 hours). Operation history is stored in memory for system diagnostics and troubleshooting.

Softening Resin

The ion exchange media is a high quality, strong acid softener (Cation) resin in the sodium (Na) form with a very high whole bead count and no color throw. It is physically hard and chlorine resistant. The resin combines high operating capacity with excellent chemical and physical stability for long dependable life. Request resin specifications for details.

Resin Tank

All SC series Softeners feature noncorrosive fiberglass tanks with a one-piece thermoplastic inner liner. The tanks have a maximum working pressure rating of 150psi and a working temperature of 120°F. The tanks are NSF/ANSI Standard 61 rated and meet FDA requirements.

Brine Tank

The brine tank is a combination brine maker and salt storage vessel. It is constructed of tough, high density polyethylene and features a grid platform for maximum saturation of brine. (30" diameter and larger are not supplied with a grid.)

Brine System

Brine refill is automatically controlled by the timer/controller to provide the correct amount of brine for proper regeneration. The refill system is complete with an air check valve, brine safety float assembly, and safety shut-off valve, all housed in a brine well providing dependable, accurate regenerations.

SERIES OPTIONS:

1. Service valve operator
2. No hard water bypass piston
3. Microswitch for lockout signal (electromechanical systems)
4. Separate source backwash/rinse
5. NXT electronic multi-tank systems (up to 4 tanks)

COMMERCIAL SOFTENING SYSTEMS

BWS PROFESSIONAL SERIES

PIPE SIZE 2"
CONTROL VALVE 3150
POLY LINED FRP TANK
2" PIPE (2.375" OD) DISTRIBUTOR

SIZING AND DIMENSION GUIDE

Series	Mineral Tank		Under Bed		Brine Tank		Softening Capacity ¹		lbs. Salt Per Regeneration ²		Flow GPM C/P	Pressure Drop PSI C/P	BKW GPM
	Tank Size ⁴	Resin cu. ft	1/4 x 1/8	.#20	Size ^{4,5}	Salt Fill	Max	Min ³	Max	Min			
A300F31	24 x 72	10	100	100	39 x 48	2000	300K	200K	150	60	50/90	15/25	15
A450F31	30 x 72	15	150	150	39 x 48	2000	450K	300K	225	90	70/103	15/25	25
A600F31	36 x 72	20	250	250	42 x 60	3000	600K	400K	300	120	80/103	15/25	35
A900F31	42 x 72	30	300	300	42 x 60	3000	900K	600K	450	180	80/103	15/25	45
A1200F31	48 x 72	40	450	450	50 x 60	4500	1200K	800K	600	240	80/103	15/25	60

C=Continuous P=Peak

ORDERING SELECTION GUIDE

Series	TIME CLOCK		METERED			Space Required W x L x H	Shipping Weight (lbs.)
	12-DAY PART #	ELECTRIC PART #	STANDARD RANGE* PART #	EXTENDED RANGE** PART #	XT*** ELECTRONIC PART #		
A300F31	SC4T300	SC4TE300	SC4M300	SC4MX300	SC4ME300	41" x 69" x 88"	1020
A450F31	SC4T450	SC4TE450	SC4M450	SC4MX450	SC4ME450	41" x 75" x 88"	1470
A600F31	SC4T600	SC4TE600	SC4M600	SC4MX600	SC4ME600	41" x 81" x 88"	2015
A900F31	SC4T900	SC4TE900	SC4M900	SC4MX900	SC4ME900	44" x 90" x 106"	3035
A1200F31	SC4T1200	SC4TE1200	SC4M1200	SC4MX1200	SC4ME1200	52" x 104" x 106"	3960

For 7-Day Timer option, add 7D to the item part number as shown here: SC4T60 to SC4T7D60.

For No Hard Water Bypass Piston Option (NHWBP), add N to the item part number as shown here: SC4T7DN60

For System 5, 6, 9, or 14, add S5, S6, S9, or S14 to the end of the item number as shown here: SC4ME60S6. Note: Only ME units are available in S5, S6, S9, or S14 configurations.

See page 47 for details.

KEY TO THE NOTATIONS ABOVE:

- Capacities are based on resin manufacturers' data and are dependant upon influent water TDS, temperature, bed depth, pressure, and flow rates. The raw water is to be free of oil, color and turbidity.
- All units from BWS are set at minimum salt settings.
- Use the minimum capacity when sizing units.
- Pipe sizes, tank sizes, and space requirements are in inches.
- 30" and larger brine tanks have no grid plate

Meter Ranges:

- * 2" Meter: Standard Range = 21,250 gallons
- ** 2" Meter: Extended Range = 106,250 gallons
- ***XT Electronic Meter: 9,999,999 gallons

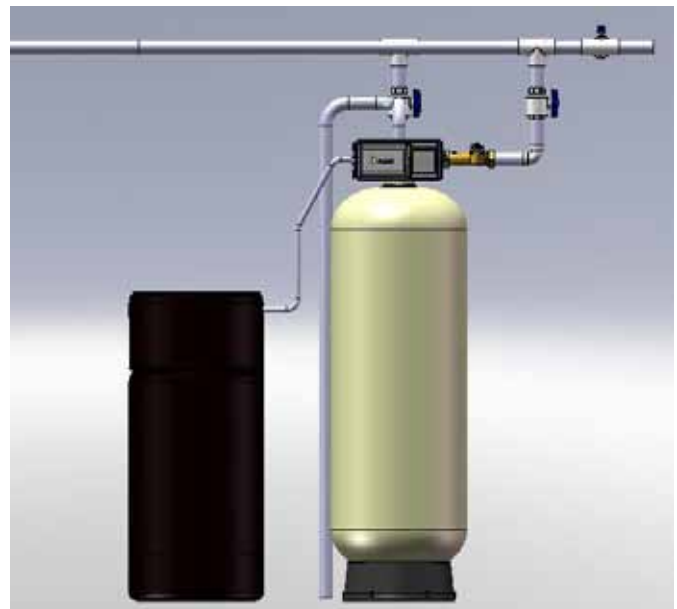

COMMERCIAL SOFTENING SYSTEMS

BWS PROFESSIONAL SERIES

**PIPE SIZE 3"
CONTROL VALVE 3900
POLY LINED FRP TANK
3" PIPE (3.5" OD) DISTRIBUTOR**

Commercial Water Softeners described here are suitable for applications ranging from 200,000 to 1,200,000 grains of hardness removal capacity at flow rates of 50 to 280 gpm depending on the system selected. Installations might include restaurants, car washes, laundromats, small boilers, and other commercial applications.

Control Valve

The 3900 sequence control valve operates on commands from the valve controller. A hydraulically balanced piston glides effortlessly along noncorrosive spacers and seals to a precise position to provide controlled backwash, brine draw/slow rinse, fast rinse and brine refill as well as the service cycle. The precision motor-driven valve performs in the toughest applications and is made of high quality lead free brass for a long and reliable life.

Standard Control Valve Features:

- Electromechanical or electronic controller
- Time clock or demand initiated regeneration
- Lead-free brass constructed valve
- Environmental NEMA 3R valve cover
- 1-1/2" female pipe threaded inlet and outlet connection
- 1-1/4" female pipe threaded drain connection
- 3" pipe (3.5" OD) distributor
- Working pressure range 20 – 125psi
- Working temperature range 34-110°F
- Valve Cv 18gpm @1psi pressure drop

Controller

Electromechanical 7 or 12 day timers operate on 120v and initiate the regeneration cycle at 2AM on the selected days. Days are selected by extending the lever on the day's wheel. 7 day timers are used for specific single day weekly regeneration; 12 day timers offer flexible regeneration frequency from daily to 6, 4, 3, or 2 day intervals. The duration of the cycles is adjusted by positioning pins on the timer wheel. Metered units regenerate at 2AM after the pre-set volume of water has been softened. Volume is set on the meter dial and is calculated on unit capacity and water hardness.

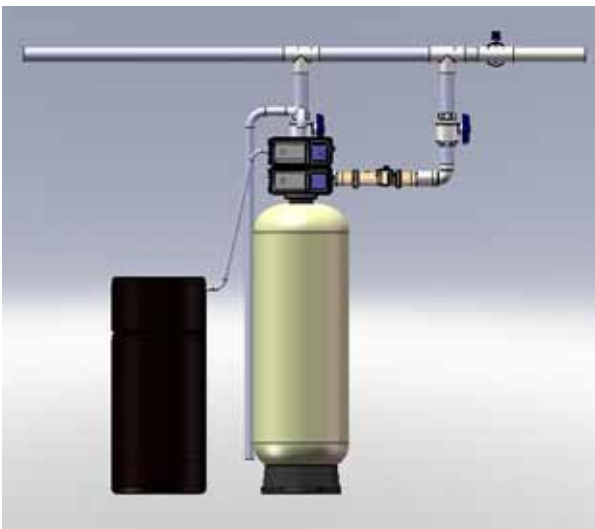

Electronic programmable 24v microprocessor controller offers complete flexibility for setting regeneration time, frequency, and cycle duration (combined time up to 16 hours). The commercial NXT controller has a full text, two-line sixteen character LCD backlit display. Meter or Remote signal (immediate or delayed) or controller initiated regeneration selectable. Remote lockout input and a 3amp fused programmable auxiliary Dry Contact Relay provided for system pump start/stop. Programmed operating parameters are stored in permanent memory and time of day is maintained during power outages (12 hours). Operation history is stored in memory for system diagnostics and troubleshooting.

Softening Resin

The ion exchange media is a high quality, strong acid softener (Cation) resin in the sodium (Na) form with a very high whole bead count and no color throw. It is physically hard and chlorine resistant. The resin combines high operating capacity with excellent chemical and physical stability for long dependable life. Request resin specifications for details.

Resin Tank

All SC series Softeners feature noncorrosive fiberglass tanks with a one-piece thermoplastic inner liner. The tanks have a maximum working pressure rating of 150psi and a working temperature of 120°F. The tanks are NSF/ANSI Standard 61 rated and meet FDA requirements.

Brine Tank

The brine tank is a combination brine maker and salt storage vessel. It is constructed of tough, high density polyethylene and features a grid platform for maximum saturation of brine. (30" diameter and larger are not supplied with a grid.)

Brine System

Brine refill is automatically controlled by the timer/controller to provide the correct amount of brine for each regeneration. The refill system is complete with an air check valve, brine safety float assembly, and safety shut-off valve, all housed in a brine well providing dependable, accurate regenerations.

SERIES OPTIONS:

1. No hard water bypass piston
2. Separate source backwash/rinse
3. Microswitch for lockout signal (electromechanical systems)
4. Service valve operator
5. NXT electronic multi-tank systems (up to 4 tanks)

COMMERCIAL SOFTENING SYSTEMS

BWS PROFESSIONAL SERIES

PIPE SIZE 3"
CONTROL VALVE 3900
POLY LINED FRP TANK
3" PIPE (3.5" OD) DISTRIBUTOR

SIZING AND DIMENSION GUIDE

Series	Mineral Tank		Under Bed		Brine Tank		Softening Capacity ¹		lbs. Salt Per Regeneration ²		Flow GPM C/P	Pressure Drop PSI C/P	BKW GPM
	Tank Size ⁴	Resin cu. ft	1/4 x 1/8	.#20	Size ^{4,5}	Salt Fill	Max	Min ³	Max	Min			
A300F39	24 x 72	10	100	100	39 x 48	2000	300K	200K	150	60	50/90	15/25	15
A450F39	30 x 72	15	150	150	39 x 48	2000	450K	300K	225	90	70/120	15/25	25
A600F39	36 x 72	20	250	250	42 x 60	3000	600K	400K	300	120	100/160	15/25	35
A900F39	42 x 72	30	300	300	42 x 60	3000	900K	600K	450	180	150/240	15/25	45
A1200F39	48 x 72	40	450	450	50 x 60	4500	1200K	800K	600	240	200/280	15/25	60

C=Continuous P=Peak

ORDERING SELECTION GUIDE

Series	TIME CLOCK		METERED				Space Required W x L x H	Shipping Weight (lbs.)
	12-DAY PART #	ELECTRIC PART #	STANDARD RANGE* PART #	EXTENDED RANGE** PART #	XT*** ELECTRONIC PART #			
A300F39	SC5T300	SC5TE300	SC5M300	SC5MX300	SC5ME300	41" x 69" x 88"	1095	
A450F39	SC5T450	SC5TE450	SC5M450	SC5MX450	SC5ME450	41" x 75" x 88"	1545	
A600F39	SC5T600	SC5TE600	SC5M600	SC5MX600	SC5ME600	41" x 81" x 88"	2090	
A900F39	SC5T900	SC5TE900	SC5M900	SC5MX900	SC5ME900	44" x 90" x 106"	3110	
A1200F39	SC5T1200	SC5TE1200	SC5M1200	SC5MX1200	SC5ME1200	52" x 104" x 106"	4035	

For 7-Day Timer option, add 7D to the item part number as shown here: SC5T60 to SC5T7D60.

For No Hard Water Bypass Piston Option (NHWBP), add N to the item part number as shown here: SC5T7DN60

For System 5, 6, 9, or 14, add S5, S6, S9, or S14 to the end of the item number as shown here: SC5ME60S6. Note: Only ME units are available in S5, S6, S9, or S14 configurations.

See page 47 for details.

KEY TO THE NOTATIONS ABOVE:

1. Capacities are based on resin manufacturers' data and are dependant upon influent water TDS, temperature, bed depth, pressure, and flow rates. The raw water is to be free of oil, color and turbidity.
2. All units from BWS are set at minimum salt settings.
3. Use the minimum capacity when sizing units.
4. Pipe sizes, tank sizes, and space requirements are in inches.
5. 30" and larger brine tanks have no grid plate

Meter Ranges:

- * 3" Meter: Standard Range = 63,750 gallons
- ** 3" Meter: Extended Range = 318,750 gallons
- ***XT Electronic Meter: 9,999,999 gallons

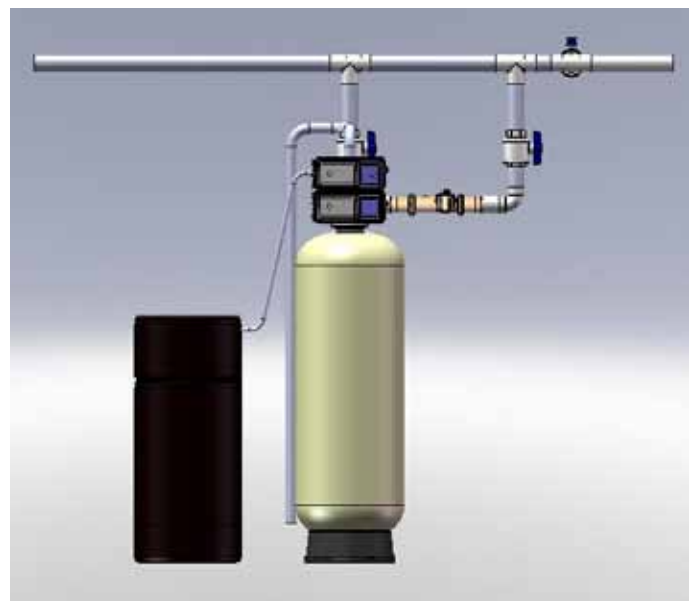

COMMERCIAL SOFTENING SYSTEMS

TWIN ALTERNATING

BWS PROFESSIONAL SERIES

PIPE SIZE 1"

CONTROL VALVE 9000

POLY LINED FRP TANK

3/4" PIPE (1.05" OD) DISTRIBUTOR

Commercial Water Softeners described here are suitable for applications ranging from 30,000 to 120,000 grains of hardness removal capacity at flow rates of 10 to 24 gpm depending on the system selected. Installations might include restaurants, car washes, laundromats, small boilers, and other light commercial applications. The unit is a System 7 twin alternating system where one unit is in service and the other unit is in standby. The off-line unit is regenerated with treated water from the on-line unit prior to going in standby.

Control Valve

The 9000 sequence control valve operates on commands from the valve controller. A hydraulically balanced piston glides effortlessly along noncorrosive spacers and seals to a precise position to provide controlled backwash, brine draw/slow rinse, fast rinse and brine refill as well as the service cycle. The precision motor-driven valve performs in the toughest applications and is made of high quality lead free brass for a long and reliable life.

Standard Control Valve Features:

- Electromechanical or electronic controller
- Lead-free brass constructed valve
- Environmental NEMA 3R valve cover
- 1" female pipe threaded inlet and outlet connection
- 1/2" male pipe threaded drain connection
- 3/4" pipe (1.05" OD) distributor
- Working pressure range 20 – 125psi
- Working temperature range 34-110°F
- Valve Cv 5.1 gpm @1psi pressure drop

Water Meter

A water meter is standard on all models. Regeneration is initiated when a pre-set volume of water is softened. Once the meter zeroes out, the system automatically switches tanks and the exhausted tank immediately goes into regeneration and the standby tank into service. Once the regeneration cycle is complete, the tank goes into standby mode.

Controller

Electromechanical Regeneration cycle is initiated by the meter after a pre-set volume of water has been softened. The duration of the cycles is adjusted by positioning pins on the timer wheel.



Electronic programmable 24v microprocessor controller offers complete flexibility for setting gallonage throughput and cycle duration (combined time up to 16 hours). The commercial NXT controller has a full text, two-line sixteen character LCD backlit display. Meter or Remote signal (immediate or delayed) or controller initiated regeneration selectable. Remote lockout input and a 3amp fused programmable auxiliary Dry Contact Relay provided for system pump start/stop. Programmed operating parameters are stored in permanent memory and time of day is maintained during power outages (12 hours). Operation history is stored in memory for system diagnostics and troubleshooting.

Softening Resin

The ion exchange media is a high quality, strong acid softener (Cation) resin in the sodium (Na) form with a very high whole bead count and no color throw. It is physically hard and chlorine resistant. The resin combines high operating capacity with excellent chemical and physical stability for long dependable life. Request resin specifications for details.

Resin Tanks

All SC series Softeners feature noncorrosive fiberglass tanks with a one-piece thermoplastic inner liner. The tanks have a maximum working pressure rating of 150psi and a working temperature of 120°F. The tanks are NSF/ANSI Standard 61 rated and meet FDA requirements.

Brine Tank

The brine tank is a combination brine maker and salt storage vessel. It is constructed of tough, high density polyethylene and features a grid platform for maximum saturation of brine.

Brine System

Brine refill is automatically controlled by the timer/controller to provide the correct amount of brine for each regeneration. The refill system is complete with an air check valve, brine safety float assembly, and safety shut-off valve, all housed in a brine well providing dependable, accurate regenerations.

SERIES OPTIONS:

- Hot water 150 °
- SXT electronic controller (60,000 gallon meter range)
- 3/4" meter
 - Standard range (125 - 2,100 gallons)
 - Extended range (625 - 10,500 gallons)

Notes:

- 3/4" meter option is supplied with 3/4" bypass valve
- Bypass valve not available with 1" metered valves

COMMERCIAL SOFTENING SYSTEMS

BWS PROFESSIONAL SERIES

TWIN ALTERNATING

PIPE SIZE 1"
CONTROL VALVE 9000
POLY LINED FRP TANK
3/4" PIPE (1.05" OD) DISTRIBUTOR

SIZING AND DIMENSION GUIDE

Series	Mineral Tank		Under Bed #20 Gravel ⁵	Brine Tank		Softening Capacity ¹		lbs. Salt Per Regeneration ²		Flow GPM C/P	Pressure Drop PSI		BKW GPM
	Tank Size ⁴	Resin ⁵ cu. ft		Size ⁴	Salt Fill	Max	Min ³	Max	Min		C/P	C/P	
A30F90	9 x 48	1	10	18 x 40	400	30K	20K	15	6	10/11	15/25	2	
A45F90	10 x 54	1.5	10	18 x 40	400	45K	30K	22.5	9	10/14	15/25	2.4	
A60F90	12 x 52	2	20	24 x 41	600	60K	40K	30	12	10/20	15/25	4	
A75F90	13 x 54	2.5	30	24 x 41	600	75K	50K	37.5	15	15/21	15/25	5	
A90F90	14 x 65	3	40	24 x 41	600	90K	60K	45	18	17/22	15/25	5	
A105F90	16 x 65	3.5	50	24 x 41	600	105K	70K	52.5	21	17/23	15/25	7	
A120F90	16 x 65	4	50	24 x 41	600	120K	80K	60	24	17/24	15/25	7	

C=Continuous P=Peak

ORDERING SELECTION GUIDE

Series	STANDARD*	EXTENDED**	XT***		Space Required W x L x H	Shipping Weight (lbs.)
	RANGE PART #	RANGE PART #	ELECTRONIC PART #			
A30F90	SC8M30	SC8MX30	SC8ME30	Twin Alt Softener	18" x 42" x 59"	230
A45F90	SC8M45	SC8MX45	SC8ME45	Twin Alt Softener	18" x 44" x 65"	290
A60F90	SC8M60	SC8MX60	SC8ME60	Twin Alt Softener	24" x 48" x 63"	400
A75F90	SC8M75	SC8MX75	SC8ME75	Twin Alt Softener	24" x 50" x 65"	460
A90F90	SC8M90	SC8MX90	SC8ME90	Twin Alt Softener	24" x 58" x 76"	500
A105F90	SC8M105	SC8MX105	SC8ME105	Twin Alt Softener	24" x 62" x 76"	625
A120F90	SC8M120	SC8MX120	SC8ME120	Twin Alt Softener	24" x 62" x 76"	650



KEY TO THE NOTATIONS ABOVE:

- Capacities are based on resin manufacturers' data and are dependant upon influent water TDS, temperature, bed depth, pressure, and flow rates. The raw water is to be free of oil, color and turbidity.
- All units from BWS are set at minimum salt settings.
- Use the minimum capacity when sizing units.
- Pipe sizes, tank sizes, and space requirements are in inches.
- Quantity listed is per vessel.

Meter Ranges:

- * 1" Meter: Standard Range = 5,100 gallons
- ** 1" Meter: Extended Range = 25,500 gallons
- ***XT Electronic Meter: 9,999,999 gallons



Maximum System Pressure 125 psi
Maximum System Temperature 110°

COMMERCIAL SOFTENING SYSTEMS

TWIN ALTERNATING

BWS PROFESSIONAL SERIES

PIPE SIZE 1.5"
CONTROL VALVE 9500
POLY LINED FRP TANK
1.5" PIPE (1.90" OD) DISTRIBUTOR

Light Commercial Water Softeners described here are suitable for applications ranging from 40,000 to 300,000 grains of hardness removal capacity at flow rates of 10 to 49 gpm depending on the system selected. Installations might include restaurants, car washes, laundromats, boiler feed, and other light commercial applications. The unit is a System 7 twin alternating system where one unit is in service and the other unit is in standby. The off-line unit is regenerated with treated water from the on-line unit prior to going in standby.

Control Valve

The sequence control valve operates on commands from the valve controller. A hydraulically balanced piston glides effortlessly along noncorrosive spacers and seals to a precise position. The precision motor-driven valve performs in the toughest applications and is made of high quality brass for a long and reliable life. A single valve regenerates and controls flow through both resin tanks.

Standard Control Valve Features:

- Electromechanical or electronic controller
- Lead-free brass constructed valve
- Environmental NEMA 3R valve cover
- 1-1/2" female pipe threaded inlet and outlet connection
- 1" male pipe threaded drain connection
- 1-1/2" pipe (1.90" OD) distributor
- Working pressure range 20 – 125psi
- Working temperature range 34-110°F
- Valve Cv 11.1 gpm @1psi pressure drop

Water Meter

A water meter is standard on all models. Regeneration is initiated when a pre-set volume of water is softened. Once the meter zeroes out, the system automatically switches tanks and the exhausted tank immediately goes into regeneration and the standby tank into service. Once the regeneration cycle is complete, the tank goes into standby mode.

Controller

Electromechanical Regeneration cycle is initiated by the meter after a pre-set volume of water has been softened. The duration of the cycles is adjusted by positioning pins on the timer wheel.

Electronic programmable 24v microprocessor controller offers complete flexibility for setting gallonage throughput and cycle duration (combined time up to 16 hours). The commercial NXT controller has a full text, two-line sixteen character LCD backlit display. Meter or Remote signal (immediate or delayed) or controller initiated regeneration selectable. Remote lockout input and a 3amp fused programmable auxiliary Dry Contact Relay provided for system pump start/stop. Programmed operating parameters are stored in permanent memory and time of day is maintained during power outages (12 hours). Operation history is stored in memory for system diagnostics and troubleshooting.

Softening Resin

The ion exchange media is a high quality, strong acid softener (Cation) resin in the sodium (Na) form with a very high whole bead count and no color throw. It is physically hard and chlorine resistant. The resin combines high operating capacity with excellent chemical and physical stability for long dependable life. Request resin specifications for details.

Resin Tanks

All SC series Softeners feature noncorrosive fiberglass tanks with a one-piece thermoplastic inner liner. The tanks have a maximum working pressure rating of 150psi and a working temperature of 120°F. The tanks are NSF/ANSI Standard 61 rated and meet FDA requirements.

Brine Tank

The brine tank is a combination brine maker and salt storage vessel. It is constructed of tough, high density polyethylene and features a grid platform for maximum saturation of brine.

Brine System

Brine refill is automatically controlled by the timer/controller to provide the correct amount of brine for each regeneration. The refill system is complete with an air check valve, brine safety float assembly, and safety shut-off valve, all housed in a brine well providing dependable, accurate regenerations.



SERIES OPTIONS:

1. Low-flow meter, sleeved to 1"
2. Hot water (150°)

COMMERCIAL SOFTENING SYSTEMS

BWS PROFESSIONAL SERIES

TWIN ALTERNATING

PIPE SIZE 1.5"
CONTROL VALVE 9500
POLY LINED FRP TANK
1.5" PIPE (1.90" OD) DISTRIBUTOR

SIZING AND DIMENSION GUIDE

Series	Mineral Tank		Under Bed 1/4 x 1/8 .#20	Brine Tank		Softening Capacity ¹		lbs. Salt Per Regeneration ²		Flow GPM C/P	Pressure Drop PSI C/P	BKW GPM
	Tank Size ⁴	Resin ^{4,6} cu. ft		Size ^{4,5}	Salt Fill	Max	Min ³	Max	Min			
A60F95	12 x 52	2	20	24 x 41	600	60K	40K	30	12	10/20	15/25	4
A75F95	13 x 54	2.5	30	24 x 41	600	75K	50K	37.5	15	12/24	15/25	5
A90F95	14 x 65	3	40	24 x 41	600	90K	60K	45	18	15/30	15/25	5
A105F95	16 x 65	3.5	50	24 x 41	600	105K	70K	52.5	21	20/40	15/25	7
A120F95	16 x 65	4	50	24 x 41	600	120K	80K	60	24	20/40	15/25	7
A150F95	21 x 62	5	100	24 x 50	800	150K	100K	75	30	25/48	15/25	12
A180F95	21 x 62	6	100	24 x 50	800	180K	120K	90	36	30/48	15/25	12
A210F95	21 x 62	7	100	24 x 50	800	210K	140K	105	42	34/49	15/25	12
A240F95	24 x 72	8	100	30 x 48	1200	240K	160K	120	48	37/49	15/25	15
A270F95	24 x 72	9	100	39 x 48	2000	270K	180K	133	54	37/49	15/25	15
A300F95	24 x 72	10	100	39 x 48	2000	300K	200K	150	60	37/49	15/25	15

ORDERING SELECTION GUIDE

C=Continuous P=Peak

Series	STANDARD*	EXTENDED**	XT***	Space Required W x L x H	Shipping Weight (lbs.)	
	RANGE PART #	RANGE PART #	ELECTRONIC PART #			
A60F95	SC6M60	SC6MX60	SC6ME60	Twin Alt Softener	26" x 52" x 68"	450
A75F95	SC6M75	SC6MX75	SC6ME75	Twin Alt Softener	26" x 56" x 70"	500
A90F95	SC6M90	SC6MX90	SC6ME90	Twin Alt Softener	26" x 58" x 81"	600
A105F95	SC6M105	SC6MX105	SC6ME105	Twin Alt Softener	26" x 60" x 81"	680
A120F95	SC6M120	SC6MX120	SC6ME120	Twin Alt Softener	26" x 60" x 81"	725
A150F95	SC6M150	SC6MX150	SC6ME150	Twin Alt Softener	26" x 72" x 78"	950
A180F95	SC6M180	SC6MX180	SC6ME180	Twin Alt Softener	26" x 72" x 78"	1050
A210F95	SC6M210	SC6MX210	SC6ME210	Twin Alt Softener	26" x 72" x 78"	1200
A240F95	SC6M240	SC6MX240	SC6ME240	Twin Alt Softener	32" x 82" x 88"	1425
A270F95	SC6M270	SC6MX270	SC6ME270	Twin Alt Softener	41" x 96" x 88"	1550
A300F95	SC6M300	SC6MX300	SC6ME300	Twin Alt Softener	41" x 96" x 88"	1650

KEY TO THE NOTATIONS ABOVE:

1. Capacities are based on resin manufacturers' data and are dependant upon influent water TDS, temperature, bed depth, pressure, and flow rates. The raw water is to be free of oil, color and turbidity.
2. All units from BWS are set at minimum salt settings.
3. Use the minimum capacity when sizing units.
4. Pipe sizes, tank sizes, and space requirements are in inches.
5. 30" and larger brine tanks have no grid plate
6. Quantity listed is per vessel

Meter Ranges:

- * 1-1/2" Meter: Standard Range = 10,625 gallons
- ** 1-1/2" Meter: Extended Range = 53,125 gallons
- ***XT Electronic Meter: 9,999,999 gallons



Maximum System Pressure 125 psi
Maximum System Temperature 110°

COMMERCIAL SOFTENING SYSTEMS

TWIN ALTERNATING

BWS PROFESSIONAL SERIES

**PIPE SIZE 2"
CONTROL VALVE 2900
POLY LINED FRP TANK
1.5" PIPE (1.90" OD) DISTRIBUTOR**

Commercial Water Softeners described here are suitable for applications ranging from 60,000 to 600,000 grains of hardness removal capacity at flow rates of 15 to 105 gpm depending on the system selected. Installations might include restaurants, car washes, laundromats, small boilers, and other commercial applications.

Control Valve

The 2900 sequence control valve operates on commands from the valve controller. A hydraulically balanced piston glides effortlessly along noncorrosive spacers and seals to a precise position to provide controlled backwash, brine draw/slow rinse, fast rinse and brine refill as well as the service cycle. The precision motor-driven valve performs in the toughest applications and is made of high quality lead free brass for a long and reliable life.

Standard Control Valve Features:

- Electromechanical or electronic controller
- Lead-free brass constructed valve
- Environmental NEMA 3R valve cover
- 2" female pipe threaded inlet and outlet connection
- 1" male pipe threaded drain connection
- 1.5" pipe (1.90" OD) distributor
- Working pressure range 20 – 125psi
- Working temperature range 34-110°F
- Valve Cv 27gpm @1psi pressure drop

Water Meter

A water meter is standard on all models. Regeneration is initiated when a pre-set volume of water is softened. Once the meter zeroes out, the system automatically switches tanks and the exhausted tank immediately goes into regeneration and the standby tank into service. Once the regeneration cycle is complete, the tank goes into standby mode.

Controller

Electromechanical Regeneration cycle is initiated by the meter after a pre-set volume of water has been softened. The duration of the cycles is adjusted by positioning pins on the timer wheel.

Electronic programmable 24v microprocessor controller offers complete flexibility for setting gallonage throughput and cycle duration (combined time up to 16 hours). The commercial NXT controller has a full text, two-line sixteen character LCD backlit display. Meter or Remote signal (immediate or delayed) or controller initiated regeneration selectable. Remote lockout input and a 3amp fused programmable auxiliary Dry Contact Relay provided for system pump start/stop. Programmed operating parameters are stored in permanent memory and time of day is maintained during power outages (12 hours). Operation history is stored in memory for system diagnostics and troubleshooting.

Softening Resin

The ion exchange media is a high quality, strong acid softener (Cation) resin in the sodium (Na) form with a very high whole bead count and no color throw. It is physically hard and chlorine resistant. The resin combines high operating capacity with excellent chemical and physical stability for long dependable life. Request resin specifications for details.

Resin Tanks

All SC series Softeners feature noncorrosive fiberglass tanks with a one-piece thermoplastic inner liner. The tanks have a maximum working pressure rating of 150psi and a working temperature of 120°F. The tanks are NSF/ANSI Standard 61 rated and meet FDA requirements.

Brine Tank

The brine tank is a combination brine maker and salt storage vessel. It is constructed of tough, high density polyethylene and features a grid platform for maximum saturation of brine. (30" diameter and larger are not supplied with a grid.)

Brine System

Brine refill is automatically controlled by the timer/controller to provide the correct amount of brine for each regeneration. The refill system is complete with an air check valve, brine safety float assembly, and safety shut-off valve, all housed in a brine well providing dependable, accurate regenerations.



SERIES OPTIONS:

1. Microswitch for lockout signal (electromechanical systems)
2. Service valve operator
3. Skid mounted

COMMERCIAL SOFTENING SYSTEMS

BWS PROFESSIONAL SERIES

TWIN ALTERNATING

PIPE SIZE 2"

CONTROL VALVE 2900

POLY LINED FRP TANK

1.5" PIPE (1.90" OD) DISTRIBUTOR

SIZING AND DIMENSION GUIDE

Series	Mineral Tank Size ^{4,6}	Tank Resin cu. ft	Under Bed 1/4 x 1/8 .#20		Brine Tank		Softening Capacity ¹		lbs. Salt Per Regeneration ²		Flow GPM C/P	Pressure Drop PSI C/P	BKW GPM
					Size ^{4,5}	Salt Fill	Max	Min ³	Max	Min			
A90F29TA	14 x 65	3		40	24 x 41	600	90K	60K	45	18	15/25	15/25	5
A120F29TA	16 x 65	4		50	24 x 41	600	120K	80K	60	24	20/35	15/25	7
A150F29TA	21 x 62	5		100	24 x 50	800	150K	100K	75	30	25/40	15/25	12
A180F29TA	21 x 62	6		100	24 x 50	800	180K	120K	90	36	30/48	15/25	12
A210F29TA	21 x 62	7		100	24 x 50	800	210K	140K	105	42	35/56	15/25	12
A240F29TA	24 x 72	8	100	100	30 x 48	1200	240K	160K	120	48	45/64	15/25	15
A300F29TA	24 x 72	10	100	100	39 x 48	2000	300K	200K	150	60	55/80	15/25	15
A450F29TA	30 x 72	15	150	150	39 x 48	2000	450K	300K	225	90	75/105	15/25	25
A600F29TA	36 x 72	20	250	250	39 x 48	2000	600K	400K	300	120	85/105	15/25	35

C=Continuous P=Peak

ORDERING SELECTION GUIDE

Series	STANDARD*	EXTENDED**	XT***	Space Required W x L x H	Shipping Weight (lbs.)	
	RANGE PART #	RANGE PART #	ELECTRONIC PART #			
A90F29TA	SC3M90TA	SC3MX90TA	SC3ME90TA	Twin Alt Softener	26" x 56" x 81"	600
A120F29TA	SC3M120TA	SC3MX120TA	SC3ME120TA	Twin Alt Softener	26" x 60" x 81"	725
A150F29TA	SC3M150TA	SC3MX150TA	SC3ME150TA	Twin Alt Softener	26" x 72" x 78"	950
A180F29TA	SC3M180TA	SC3MX180TA	SC3ME180TA	Twin Alt Softener	26" x 72" x 78"	1050
A210F29TA	SC3M210TA	SC3MX210TA	SC3ME210TA	Twin Alt Softener	26" x 72" x 78"	1200
A240F29TA	SC3M240TA	SC3MX240TA	SC3ME240TA	Twin Alt Softener	32" x 78" x 88"	1725
A300F29TA	SC3M300TA	SC3MX300TA	SC3ME300TA	Twin Alt Softener	41" x 78" x 88"	1925
A450F29TA	SC3M450TA	SC3MX450TA	SC3ME450TA	Twin Alt Softener	41" x 90" x 88"	2850
A600F29TA	SC3M600TA	SC3MX600TA	SC3ME600TA	Twin Alt Softener	41" x 102" x 88"	3900

KEY TO THE NOTATIONS ABOVE:

1. Capacities are based on resin manufacturers' data and are dependant upon influent water TDS, temperature, bed depth, pressure, and flow rates. The raw water is to be free of oil, color and turbidity.
2. All units from BWS are set at minimum salt settings.
3. Use the minimum capacity when sizing units.
4. Pipe sizes, tank sizes, and space requirements are in inches.
5. 30" and larger brine tanks have no grid plate.
6. Quantity listed is per vessel.

Meter Ranges:

- * 2" Meter: Standard Range = 21,250 gallons
- ** 2" Meter: Extended Range = 106,250 gallons
- ***XT Electronic Meter: 9,999,999 gallons



COMMERCIAL SOFTENING SYSTEMS

TWIN ALTERNATING

BWS PROFESSIONAL SERIES

PIPE SIZE 3"

CONTROL VALVE 3900

POLY LINED FRP TANK

3" PIPE (3.5" OD) DISTRIBUTOR

Commercial Water Softeners described here are suitable for applications ranging from 200,000 to 1,200,000 grains of hardness removal capacity at flow rates of 50 to 280 gpm depending on the system selected. Installations might include restaurants, car washes, laundromats, small boilers, and other commercial applications.

Control Valve

The 3900 sequence control valve operates on commands from the valve controller. A hydraulically balanced piston glides effortlessly along noncorrosive spacers and seals to a precise position to provide controlled backwash, brine draw/slow rinse, fast rinse and brine refill as well as the service cycle. The precision motor-driven valve performs in the toughest applications and is made of high quality lead free brass for a long and reliable life.

Standard Control Valve Features:

- Electromechanical or electronic controller
- Lead-free brass constructed valve
- Environmental NEMA 3R valve cover
- 3" female pipe threaded inlet and outlet connection
- 2" female pipe threaded drain connection
- 3" pipe (3.5" OD) distributor
- Working pressure range 20 – 125psi
- Working temperature range 34-110°F
- Valve Cv 65gpm @1psi pressure drop

Water Meter

A water meter is standard on all models. Regeneration is initiated when a pre-set volume of water is softened. Once the meter zeroes out, the system automatically switches tanks and the exhausted tank immediately goes into regeneration and the standby tank into service. Once the regeneration cycle is complete, the tank goes into standby mode.

Controller

Electromechanical Regeneration cycle is initiated by the meter after a pre-set volume of water has been softened. The duration of the cycles is adjusted by positioning pins on the timer wheel.

Electronic programmable 24v microprocessor controller offers complete flexibility for setting gallonage throughput and cycle duration (combined time up to 16 hours). The commercial NXT controller has a full text, two-line sixteen character LCD backlit display. Meter or Remote signal (immediate or delayed) or controller initiated regeneration selectable. Remote lockout input and a 3amp fused programmable auxiliary Dry Contact Relay provided for system pump start/stop. Programmed operating parameters are stored in permanent memory and time of day is maintained during power outages (12 hours). Operation history is stored in memory for system diagnostics and troubleshooting.

Softening Resin

The ion exchange media is a high quality, strong acid softener (Cation) resin in the sodium (Na) form with a very high whole bead count and no color throw. It is physically hard and chlorine resistant. The resin combines high operating capacity with excellent chemical and physical stability for long dependable life. Request resin specifications for details.

Resin Tanks

All SC series Softeners feature noncorrosive fiberglass tanks with a one-piece thermoplastic inner liner. The tanks have a maximum working pressure rating of 150psi and a working temperature of 120°F. The tanks are NSF/ANSI Standard 61 rated and meet FDA requirements.

Brine Tank

The brine tank is a combination brine maker and salt storage vessel. It is constructed of tough, high density polyethylene and features a grid platform for maximum saturation of brine.

Brine System

Brine refill is automatically controlled by the timer/controller to provide the correct amount of brine for each regeneration. The refill system is complete with an air check valve, brine safety float assembly, and safety shut-off valve, all housed in a brine well providing dependable, accurate regenerations.

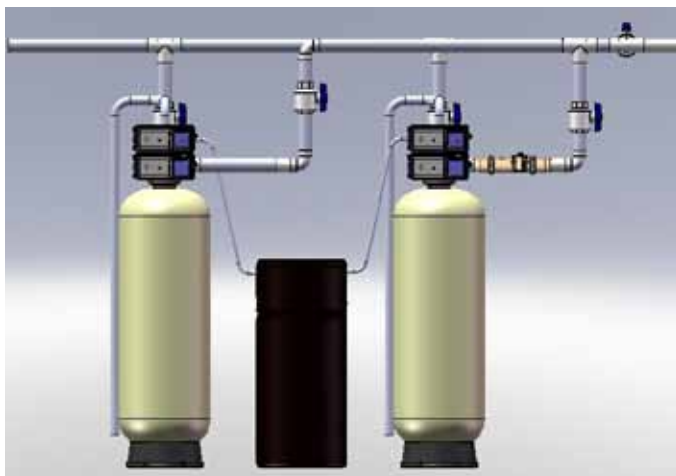

SERIES OPTIONS:

1. Microswitch for lockout signal (electromechanical systems)
2. Service valve operator
3. NXT electronic multi-tank systems (up to 4 tanks)

COMMERCIAL SOFTENING SYSTEMS

BWS PROFESSIONAL SERIES

TWIN ALTERNATING

PIPE SIZE 3"
CONTROL VALVE 3900TA
POLY LINED FRP TANK
3" PIPE (3.5" OD) DISTRIBUTOR

SIZING AND DIMENSION GUIDE

Series	Mineral Tank Size ^{4, 6}	Tank Resin cu. ft	Under Bed 1/4 x 1/8 .#20	Brine Tank		Softening Capacity ¹		lbs. Salt Per Regeneration ²		Flow GPM C/P	Pressure Drop PSI C/P	BKW GPM	
				Size ^{4, 5}	Salt Fill	Max	Min ³	Max	Min				
A300F39	24 x 72	10	100	100	39 x 48	2000	300K	200K	150	60	50/90	15/25	15
A450F39	30 x 72	15	150	150	39 x 48	2000	450K	300K	225	90	70/120	15/25	25
A600F39	36 x 72	20	250	250	39 x 60	2700	600K	400K	300	120	100/160	15/25	35
A900F39	42 x 72	30	300	300	50 x 60	3000	900K	600K	450	180	150/240	15/25	50
A1200F39	48 x 72	40	450	450	50 x 60	4500	1200K	800K	600	240	200/280	15/25	70

C=Continuous P=Peak

ORDERING SELECTION GUIDE

Series	TIME CLOCK		METERED			Space Required W x L x H	Shipping Weight (lbs.)
	12-DAY PART #	ELECTRIC PART #	STANDARD RANGE* PART #	EXTENDED RANGE** PART #	XT*** ELECTRONIC PART #		
A300F39TA	SC5T300TA	SC5TE300TA	SC5M300TA	SC5MX300TA	SC5ME300TA	41" x 78" x 96"	2000
A450F39TA	SC5T450TA	SC5TE450TA	SC5M450TA	SC5MX450TA	SC5ME450TA	41" x 90" x 96"	2925
A600F39TA	SC5T600TA	SC5TE600TA	SC5M600TA	SC5MX600TA	SC5ME600TA	41" x 102" x 96"	3950
A900F39TA	SC5T900TA	SC5TE900TA	SC5M900TA	SC5MX900TA	SC5ME900TA	52" x 114" x 96"	6550
A1200F39TA	SC5T1200TA	SC5TE1200TA	SC5M1200TA	SC5MX1200TA	SC5ME1200TA	52" x 126" x 96"	8650

KEY TO THE NOTATIONS ABOVE:

1. Capacities are based on resin manufacturers' data and are dependant upon influent water TDS, temperature, bed depth, pressure, and flow rates. The raw water is to be free of oil, color and turbidity.
2. All units from BWS are set at minimum salt settings.
3. Use the minimum capacity when sizing units.
4. Pipe sizes, tank sizes, and space requirements are in inches.
5. 30" and larger brine tanks have no grid plate.
6. Quantity listed is per vessel.

Meter Ranges:

- * 3" Meter: Standard Range = 63,750 gallons
- ** 3" Meter: Extended Range = 318,750 gallons
- ***XT Electronic Meter: 9,999,999 gallons

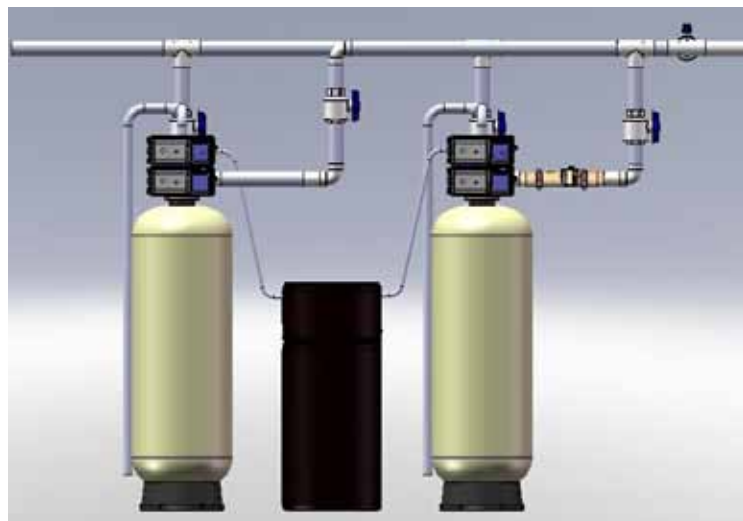

COMMERCIAL FILTRATION SYSTEMS

BWS PROFESSIONAL SERIES

PIPE SIZE 1"
CONTROL VALVE 2750
POLY LINED FRP TANK
3/4" PIPE (1.05" OD) DISTRIBUTOR

Commercial Water Treatment Filters described here are suitable for applications ranging from flow rates of 5 to 33 gpm depending on the system and media selected. Installations might include restaurants, car washes, laundromats, small boilers, and other light commercial applications.

Control Valve

The 2750 sequence control valve operates on commands from the valve controller. A hydraulically balanced piston glides effortlessly along noncorrosive spacers and seals to a precise position to provide controlled backwash, rinse, or service cycles. The precision motor-driven valve performs in the toughest applications and is made of high quality lead-free brass for a long and reliable life.

Standard Control Valve Features:

- Lead-free brass constructed valve
- WQA tested and certified to NSF/ANSI Std 61
- Environmental NEMA 3R valve cover
- 1" male pipe threaded inlet and outlet connection
- 3/4" male pipe threaded drain connection
- 3/4" pipe (1.05" OD) distributor
- 2 1/2" -8 NPSM mounting base
- Working pressure range 20 – 125psi
- Working temperature range 34-110°F
- Valve Cv 6.8gpm @1psi pressure drop

Controller

Electromechanical 7 or 12 day timers operate on 120v and initiate the backwash and rinse cycle at 2AM on the selected days. Days are selected by extending the lever on the day's wheel. 7 day timers are used for specific single day weekly regeneration; 12 day timers offer flexible regeneration frequency from daily to 6, 4, 3, or 2 day intervals. The duration of the cycles is adjusted by positioning pins on the timer wheel.

Electronic programmable 24v microprocessor controller offers complete flexibility for setting regeneration time, frequency, and cycle duration (1 - 99 minutes). The commercial XT controller has a full text, two-line sixteen character LCD backlit display. Remote signal (immediate or delayed) or controller initiated regeneration selectable. Remote lockout input and a 3amp fused programmable auxiliary Dry Contact Relay provided for system pump start/stop. Programmed operating parameters are stored in permanent memory and time of day is maintained during power outages (12 hours). Operation history is stored in memory for system diagnostics and troubleshooting.

Media Tank

All BTFseries filters feature noncorrosive fiberglass tanks with a one-piece thermoplastic inner liner. The tanks have a maximum working pressure rating of 150psi and a working temperature of 120°F. The tanks are NSF/ANSI Standard 61 rated and meet FDA requirements.



COMMERCIAL FILTRATION SYSTEMS

BWS PROFESSIONAL SERIES

PIPE SIZE 1"
CONTROL VALVE 2750
POLY LINED FRP TANK
3/4" PIPE (1.05" OD) DISTRIBUTOR

SIZING AND DIMENSION GUIDE

GENERAL SPECIFICATIONS	Filter Part Number						
	BTF9F27	BTF10F27	BTF12F27	BTF13F27	BTF14F27	BTF16F27	BTF21F27
Mineral Tank Size	9" x 48"	10" x 54"	12" x 52"	13" x 54"	14" x 65"	16" x 65"	21" x 62"
Filter Media Capacity (cu ft)	1	1-1/2	2	2-1/2	3	4	6
Approximate Freeboard (from top of tank)	18"	18"	16"	16"	26"	27"	27"
Underbed Support Gravel Required (pounds)	10	15	20	30	40	50	100
Service Flow Rate - Continuous (gpm) ¹	2.2	2.8	4	5	6	7	12
Service Flow Rate - Intermittent (gpm)	4	5	6	7	8	10	24
Backwash Rate (gpm)	4	5	7	9	10	14	25
Approx. Floor Space (DxWxH inches)	9x11x55	10x12x61	12x13x59	13x13x61	14x14x73	16x16x73	21x21x70
Approx. Shipping Weight	30	34	38	42	55	78	115

See Filtration Media Guide for selection of proper media for you filtration application. Use of a flow control in the Service line is highly recommended. Caution should always be used in sizing filters! Always choose a unit by first satisfying the Backwash Flow Rate requirement above. Consult the factory or your salesperson for application guidance.

¹Service flow rate shown is based on 5GPM per square foot of tank area and is optimal for most media. Actual field conditions or media selection may dictate higher or lower rates. TDS, pH, application, and flow rates may also affect the performance of the system.

All units shipped empty. Use filter media selection guides (pages 28 - 37).

OPTIONS:

- No untreated water bypass piston
- Separate source backwash/rinse
- Microswitch for lockout signal (electromechanical systems)
- Service valve operator
- Hot water - up to 180° F
- NXT electronic multi-tank filter systems (up to 4 tanks)



COMMERCIAL FILTRATION SYSTEMS

BWS PROFESSIONAL SERIES

PIPE SIZE 1.5"

CONTROL VALVE 2850S

POLY LINED FRP TANK

1.5" PIPE (1.90" OD) DISTRIBUTOR

Commercial Water Treatment Filters described here are suitable for applications ranging from flow rates of 10 to 70 gpm depending on the system and media selected. Installations might include restaurants, car washes, laundromats, small boilers, and other light commercial applications.

Control Valve

The 2850S sequence control valve operates on commands from the valve controller. A hydraulically balanced piston glides effortlessly along noncorrosive spacers and seals to a precise position to provide controlled backwash, rinse, or service cycles. The precision motor-driven valve performs in the toughest applications and is made of high quality lead-free brass for a long and reliable life.

Standard Control Valve Features:

- Lead-free brass constructed valve
- WQA tested and certified to NSF/ANSI Std 61
- Environmental NEMA 3R valve cover
- 1-1/2" female pipe threaded inlet and outlet connection
- 1-1/4" female pipe threaded drain connection
- 1-1/2" pipe (1.90 OD) distributor tube pilot
- 4" -8 UN mounting base
- Working pressure range 20 – 125psi
- Working temperature range 34-110°F
- Valve Cv 18gpm @1psi pressure drop



Controller

Electromechanical 7 or 12 day timers operate on 120v and initiate the backwash and rinse cycle at 2AM on the selected days. Days are selected by extending the lever on the day's wheel. 7 day timers are used for specific single day weekly regeneration; 12 day timers offer flexible regeneration frequency from daily to 6, 4, 3, or 2 day intervals. The duration of the cycles is adjusted by positioning pins on the timer wheel.

Electronic programmable 24v microprocessor controller offers complete flexibility for setting regeneration time, frequency, and cycle duration (1 - 99 minutes). The commercial XT controller has a full text, two-line sixteen character LCD backlit display. Remote signal (immediate or delayed) or controller initiated regeneration selectable. Remote lockout input and a 3amp fused programmable auxiliary Dry Contact Relay provided for system pump start/stop. Programmed operating parameters are stored in permanent memory and time of day is maintained during power outages (12 hours). Operation history is stored in memory for system diagnostics and troubleshooting.

Media Tank

All BTF series filters feature noncorrosive fiberglass tanks with a one-piece thermoplastic inner liner. The tanks have a maximum working pressure rating of 150psi and a working temperature of 120°F. The tanks are NSF/ANSI Standard 61 rated and meet FDA requirements.

COMMERCIAL FILTRATION SYSTEMS

BWS PROFESSIONAL SERIES

PIPE SIZE 1.5"
CONTROL VALVE 2850S
POLY LINED FRP TANK
1.5" PIPE (1.90" OD) DISTRIBUTOR

SIZING AND DIMENSION GUIDE

GENERAL SPECIFICATIONS	Filter Part Number						
	BTF12F28	BTF13F28	BTF14F28	BTF16F28	BTF21F28	BTF24F28	BTF30F28
Mineral Tank Size	12" x 52"	13" x 54"	14" x 65"	16" x 65"	21" x 62"	24" x 72"	30" x 72"
Filter Media Capacity (cu ft)	2	2-1/2	3	4	6	8	10
Approximate Freeboard (from top of tank)	16"	16"	26"	27"	27"	27"	27"
Underbed Support Gravel Required (pounds)	20	30	40	50	100	200 ²	300 ²
Service Flow Rate - Continuous (gpm) ¹	4	5	6	7	12	16	25
Service Flow Rate - Intermittent (gpm)	6	7	8	10	24	32	50
Backwash Rate (gpm)	7	9	10	14	25	30	50
Approx. Floor Space (DxWxH inches)	12x13x59	13x13x61	14x14x73	16x16x73	21x21x70	24x24x80	30x30x80
Approx. Shipping Weight	42	47	60	83	120	175	275

See Filtration Media Guide for selection of proper media for you filtration application. Use of a flow control in the Service line is highly recommended. Caution should always be used in sizing filters! Always choose a unit by first satisfying the Backwash Flow Rate requirement above. Consult the factory or your salesperson for application guidance.

¹Service flow rate shown is based on 5GPM per square foot of tank area and is optimal for most media. Actual field conditions or media selection may dictate higher or lower rates. TDS, pH, application, and flow rates may also affect the performance of the system.

²Use equal amounts of A7006A and A7005A gravel for best support.

All units shipped empty. Use filter media selection guides (pages 28 - 37).

OPTIONS:

- No untreated water bypass piston
- Separate source backwash/rinse
- Microswitch for lockout signal (electromechanical systems)
- Service valve operator
- Hot water - up to 180° F
- NXT electronic multi-tank filter systems (up to 4 tanks)



COMMERCIAL FILTRATION SYSTEMS

BWS PROFESSIONAL SERIES

PIPE SIZE 2"

CONTROL VALVE 3150

POLY LINED FRP TANK

2" PIPE (2.375" OD) DISTRIBUTOR

Commercial Water Treatment Filters described here are suitable for applications ranging from flow rates of 15 to 80 gpm depending on the system and media selected. Installations might include restaurants, car washes, laundromats, small boilers, and other light commercial applications.

Control Valve

The 3150 sequence control valve operates on commands from the valve controller. A hydraulically balanced piston glides effortlessly along non-corrosive spacers and seals to a precise position to provide controlled backwash, rinse, or service cycles. The precision motor-driven valve performs in the toughest applications and is made of high quality lead-free brass for a long and reliable life.

Standard Control Valve Features:

- Lead-free brass constructed valve
- WQA tested and certified to NSF/ANSI Std 61
- Environmental NEMA 3R valve cover
- 4" -8 UN mounting base
- 2" female pipe threaded inlet and outlet connection
- 2" female pipe threaded drain connection
- 2" pipe (2.375 OD) distributor tube pilot
- Working pressure range 20 – 125psi
- Working temperature range 34-110°F
- Valve Cv 24.8gpm @1psi pressure drop

Controller

Electromechanical 7 or 12 day timers operate on 120v and initiate the backwash and rinse cycle at 12AM on the selected days. Days are selected by extending the lever on the day's wheel. 7 day timers are used for specific single day weekly regeneration; 12 day timers offer flexible regeneration frequency from daily to 6, 4, 3, or 2 day intervals. The duration of the cycles is adjusted by positioning pins on the timer wheel.

Electronic programmable 24v microprocessor controller offers complete flexibility for setting regeneration time, frequency, and cycle duration (1 - 99 minutes). The commercial XT controller has a full text, two-line sixteen character LCD backlit display. Remote signal (immediate or delayed) or controller initiated regeneration selectable. Remote lockout input and a 3amp fused programmable auxiliary Dry Contact Relay provided for system pump start/stop. Programmed operating parameters are stored in permanent memory and time of day is maintained during power outages (12 hours). Operation history is stored in memory for system diagnostics and troubleshooting.

Media Tank

All BTF series filters feature noncorrosive fiberglass tanks with a one-piece thermoplastic inner liner. The tanks have a maximum working pressure rating of 150psi and a working temperature of 120°F. The tanks are NSF/ANSI Standard 61 rated and meet FDA requirements.



COMMERCIAL FILTRATION SYSTEMS

BWS PROFESSIONAL SERIES

PIPE SIZE 2"
CONTROL VALVE 3150
POLY LINED FRP TANK
2" PIPE (2.375" OD) DISTRIBUTOR

SIZING AND DIMENSION GUIDE

GENERAL SPECIFICATIONS	Filter Part Number				
	BTF21F31	BTF24F31	BTF30F31	BTF36F31	BTF42F31
Mineral Tank Size	21" x 62"	24" x 72"	30" x 72"	36" x 72"	42" x 72"
Filter Media Capacity (cu ft)	6	8	10	20	26
Approximate Freeboard (from top of tank)	27"	27"	27"	27"	27"
Underbed Support Gravel Required (pounds) ¹	100	200	300	500	600
Service Flow Rate - Continuous (gpm) ²	12	16	25	36	48
Service Flow Rate - Intermittent (gpm)	24	32	50	72	96
Backwash Rate (gpm)	25	30	50	70	95
Approx. Floor Space (DxWxH inches)	21x21x72	24x24x82	30x30x82	36x36x82	42x42x82
Approx. Shipping Weight	140	195	295	350	735

See Filtration Media Guide for selection of proper media for you filtration application. Use of a flow control in the Service line is highly recommended. Caution should always be used in sizing filters! Always choose a unit by first satisfying the Backwash Flow Rate requirement above. Consult the factory or your salesperson for application guidance.

¹Use equal amounts of A7006A and A7005A gravel for best support.

²Service flow rate shown is based on 5GPM per square foot of tank area and is optimal for most media. Actual field conditions or media selection may dictate higher or lower rates. TDS, pH, application, and flow rates may also affect the performance of the system.

All units shipped empty. Use filter media selection guides (pages 28 - 37).

OPTIONS:

- No untreated water bypass piston
- Separate source backwash/rinse
- Microswitch for lockout signal (electromechanical systems)
- Service valve operator
- Hot water - up to 180° F
- NXT electronic multi-tank filter systems (up to 4 tanks)



COMMERCIAL FILTRATION SYSTEMS

BWS PROFESSIONAL SERIES

PIPE SIZE 3"

CONTROL VALVE 3900

POLY LINED FRP TANK

3" PIPE (3.5" OD) DISTRIBUTOR

Commercial Water Treatment Filters described here are suitable for applications ranging from flow rates of 25 to 120 gpm depending on the system and media selected. Installations might include restaurants, car washes, laundromats, small boilers, and other light commercial applications.

Control Valve

The 3900 sequence control valve operates on commands from the valve controller. A hydraulically balanced piston glides effortlessly along non-corrosive spacers and seals to a precise position to provide controlled backwash, rinse, or service cycles. The precision motor-driven valve performs in the toughest applications and is made of high quality lead-free brass for a long and reliable life.

Standard Control Valve Features:

- Lead-free brass constructed valve
- WQA tested and certified to NSF/ANSI Std 61
- Environmental NEMA 3R valve cover
- 3" female pipe threaded inlet and outlet connection
- 2" female pipe threaded drain connection
- 3" pipe (3.5 OD) distributor tube pilot
- Working pressure range 20 – 125psi
- Working temperature range 34-110°F
- Valve Cv 24.8gpm @1psi pressure drop

Controller

Electromechanical 7 or 12 day timers operate on 120v and initiate the backwash and rinse cycle at 12AM on the selected days. Days are selected by extending the lever on the day's wheel. 7 day timers are used for specific single day weekly regeneration; 12 day timers offer flexible regeneration frequency from daily to 6, 4, 3, or 2 day intervals. The duration of the cycles is adjusted by positioning pins on the timer wheel.

Electronic programmable 24v microprocessor controller offers complete flexibility for setting regeneration time, frequency, and cycle duration (1 - 99 minutes). The commercial XT controller has a full text, two-line sixteen character LCD backlit display. Remote signal (immediate or delayed) or controller initiated regeneration selectable. Remote lockout input and a 3amp fused programmable auxiliary Dry Contact Relay provided for system pump start/stop. Programmed operating parameters are stored in permanent memory and time of day is maintained during power outages (12 hours). Operation history is stored in memory for system diagnostics and troubleshooting.

Media Tank

All BTF series filters feature noncorrosive fiberglass tanks with a one-piece thermoplastic inner liner. The tanks have a maximum working pressure rating of 150psi and a working temperature of 120°F. The tanks are NSF/ANSI Standard 61 rated and meet FDA requirements.

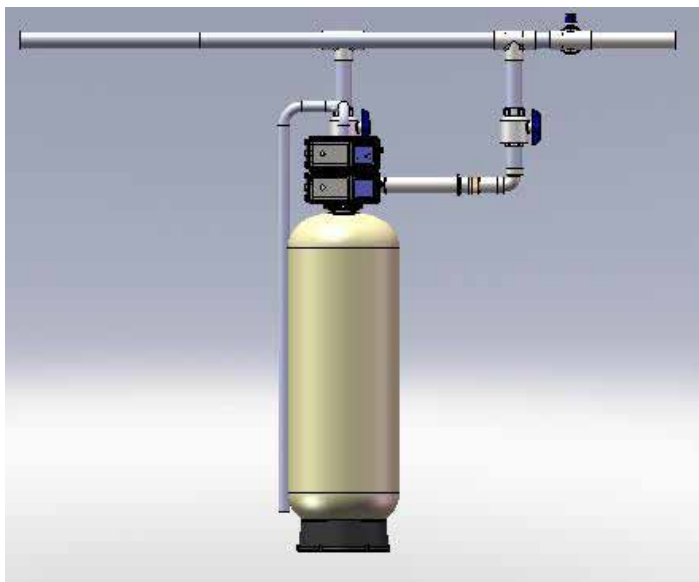

COMMERCIAL FILTRATION SYSTEMS

BWS PROFESSIONAL SERIES

PIPE SIZE 3"
CONTROL VALVE 3900
POLY LINED FRP TANK
3" PIPE (3.5" OD) DISTRIBUTOR

SIZING AND DIMENSION GUIDE

GENERAL SPECIFICATIONS	Filter Part Number			
	BTF24F39	BTF30F39	BTF36F39	BTF42F39
Mineral Tank Size	24" x 72"	30" x 72"	36" x 72"	42" x 72"
Filter Media Capacity (cu ft)	8	10	20	26
Approximate Freeboard (from top of tank)	27"	27"	27"	27"
Underbed Support Gravel Required (pounds) ¹	200	300	500	600
Service Flow Rate - Continuous (gpm) ²	16	25	36	48
Service Flow Rate - Intermittent (gpm)	32	50	72	96
Backwash Rate (gpm)	30	50	70	95
Approx. Floor Space (DxWxH inches)	24x24x82	30x30x82	36x36x82	42x42x82
Approx. Shipping Weight	240	340	390	780

See Filtration Media Guide for selection of proper media for you filtration application. Use of a flow control in the Service line is highly recommended. Caution should always be used in sizing filters! Always choose a unit by first satisfying the Backwash Flow Rate requirement above. Consult the factory or your salesperson for application guidance.

¹Use equal amounts of A7006A and A7005A gravel for best support.

²Service flow rate shown is based on 5GPM per square foot of tank area and is optimal for most media. Actual field conditions or media selection may dictate higher or lower rates. TDS, pH, application, and flow rates may also affect the performance of the system.

All units shipped empty. Use filter media selection guides (pages 28 - 37).

OPTIONS:

- No untreated water bypass piston
- Separate source backwash/rinse
- Microswitch for lockout signal (electromechanical systems)
- Service valve operator
- NXT electronic multi-tank filter systems (up to 4 tanks)

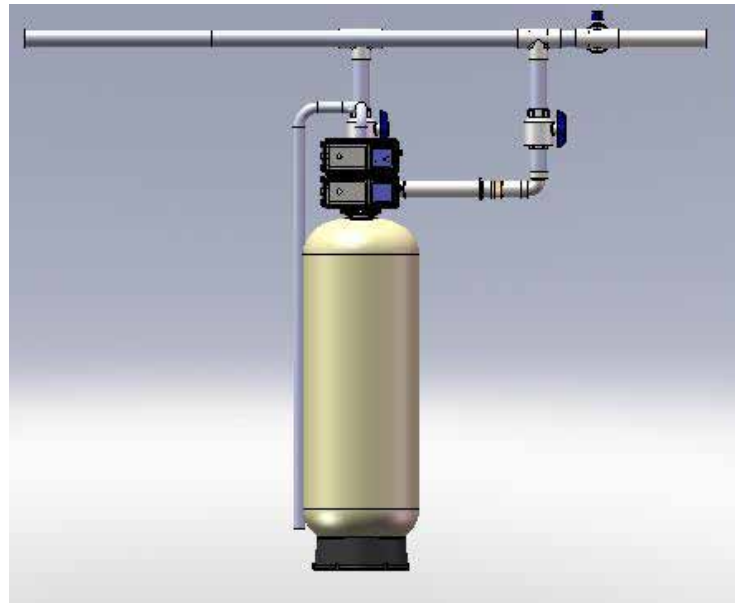

FILTRATION & SELECTIVE MEDIA

Cation Resin					
Part Number	Description	U.S. Mesh	Qty/bag	Wgt/bag	Bags/Pallet
A4000	Premium Softener Na+ Potable Water	16-50	1cf	53	42
A6001	Premium Softener Na+ Industrial	16-50	1cf	50	42
A6002	Premium Softener H+ Industrial	16-50	1cf	50	42
A6007	Premium Softener Na+ Fine Mesh	40-70	1cf	50	42
A4016	Premium Softener 10X Na+	16-50	1cf	50	42
A4078	Premium Shallow Shell SST-60 Na+	16-50	1cf	50	42
Anion Resin					
Part Number	Description	U.S. Mesh	Qty/bag	Wgt/bag	Bags/Pallet
A4044	A300 Strong Base Type II Cl Industrial	16-50	1cf	44	42
A4048	A300E Strong Base Type II Cl Potable	16-50	1cf	44	42
A6024	A-860 Strong Base Type I Tannin/Organics	16-40	1cf	44	42
A6027	A520-E Strong Base Macro Nitrate Selective	16-50	1cf	43	42
A4140	MB3710 Mixed Bed H/OH	16-40	1cf	46	42
A4140SG	UCW3700 Mixed Bed H/OH Semi-Conductor	16-40	1cf	46	42
Filter Sand					
Part Number	Description	U.S. Mesh	Qty/bag	Wgt/bag	Bags/Pallet
A7005A	1/8"x1/16" Washed Gravel	16-6 Fine	1/2cf	50	56
A7006A	1/4"x1/8" Washed Gravel	6-3 Medium	1/2cf	50	56
A7007A	1/2"x1/4" Washed Gravel	Coarse	1/2cf	50	56
Anthracite					
Part Number	Description	U.S. Mesh	Qty/bag	Wgt/bag	Bags/Pallet
A7050	#1 (0.6 x 0.8mm)	30-30	1cf	52	40
A7051	#1-1/2 (0.85 x 0.95mm)	20-18	1cf	52	40
A7052	#2 (3/16" x 3/32")	8-4	1cf	52	40
Filter Garnet					
Part Number	Description	U.S. Mesh	Qty/bag	Wgt/bag	Bags/Pallet
A7080A	#12 Coarse Garnet	1.4mm	.44cf	50	40
A7082A	#16 Medium Garnet	0.9mm	.44cf	50	40
A7086A	#50 Fine Garnet	0.4mm	.44cf	50	40
Carbon					
Part Number	Description	U.S. Mesh	Qty/bag	Wgt/bag	Bags/Pallet
A8056	Calgon Centaur Catalytic	12x40	1cf	34	40
A9030C	Calgon Acid Washed CPG-LF40	12x40	2cf	55	40
A9031C	Calgon F-300 Low Fines	8x30	2cf	55	40
A9032C	Calgon F-400 Low Fines	12x40	2cf	55	40
A9034C	Calgon F-600 Selective	8x40	1.4	40	40
A9230A	Calgon Acid Washed OLC Coconut	12x40	2cf	55	40
A9231	Calgon OLC Coconut	12x40	2cf	55	40
Neutralizer					
Part Number	Description	U.S. Mesh	Qty/bag	Wgt/bag	Bags/Pallet
A802150	Imery XO White - Medium	16x20	1/2cf	50	40
A802250	Imery Z White - Coarse	10x20	1/2cf	50	40
A802350	Imery 30-50 White - Fine	30x50	1/2cf	50	40
A802450	Imery OZ White - Very Coarse	6x4	1/2cf	50	40
A8012	Clack Corosex Mag Oxide	6x16	.66cf	50	40
A8018	Martin Marietta FlowMag	6x16	.66cf	50	40
Specialty Medias					
Part Number	Description	U.S. Mesh	Qty/bag	Wgt/bag	Bags/Pallet
A8014	Clack Filter Ag®	12x30	1cf	26	70
A8015	Chemsorb	14x40	1cf	50	40
A8006	Clack Birm®	10x40	1cf	44	40
A8033	Catalox	20x40	.4cf	50	40
A8040	Clack MTM ®	14x40	1cf	27	40
A8045	Greensand Plus	18x60	1/2cf	44	40
A5005	KDF-85 Iron & Hydrogen Sulfide	10x100	.33cf	57	48

FILTRATION MEDIA SELECTION GUIDE

MULTIMEDIA FILTER PACK

MultiMedia - Particle Filtration

Turbidity -Silt - Sediment

Filter Series	MultiMedia Pack Ordering Number	Tank Size	Service Flow Rate GPM			Backwash
			8gpm/sf	12gpm/sf	15gpm/sf	
BTF9	N52409RB	9"x48"	3.5	5	6.5	5
BTF10	N524010RB	10"x54"	5	7	8	7
BTF12	N524012RB	12"x52"	6	9	12	9
BTF13	N524013RB	13"x54"	7	11	14	11
BTF14	N524014RB	14"x65"	9	13	16	13
BTF16	N524016RB	16"x65"	11	17	21	17
BTF21	N524021RB	21"x62"	19	26	36	26
BTF24	N524024RB	24"x72"	25	29	47	29
BTF30	N524030RB	30"x72"	39	59	74	59
BTF36	N524036RB	36"x72"	59	85	106	85
BTF42	N524042RB	42"x72"	77	115	144	115
BTF48	N524048RB	48"x72"	100	150	189	155

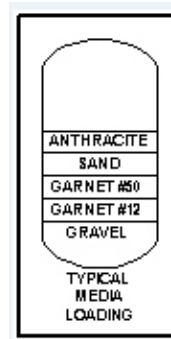

All Media Packs include the following:

MultiMedia Pack Ordering Number	#1 Anthracite	0.45-0.55 Fine Sand	Garnet #50	Garnet #12	#20 Gravel
N52409RB	18.2 Lbs	30 Lbs	15 Lbs	10 Lbs	12 Lbs
N524010RB	39 Lbs	45 Lbs	27 Lbs	20 Lbs	15 Lbs
N524012RB	52 Lbs	50 Lbs	30 Lbs	20 Lbs	25 Lbs
N524013RB	52 Lbs	55 Lbs	50 Lbs	34 Lbs	30 Lbs
N524014RB	78 Lbs	100 Lbs	68 Lbs	45 Lbs	40 Lbs
N524016RB	104 Lbs	150 Lbs	75 Lbs	40 Lbs	55 Lbs
N524021RB	156 Lbs	200 Lbs	100 Lbs	50 Lbs	100 Lbs
N524024RB	234 Lbs	300 Lbs	150 Lbs	100 Lbs	150 Lbs
N524030RB	364 Lbs	500 Lbs	250 Lbs	150 Lbs	250 Lbs
N524036RB	520 Lbs	700 Lbs	400 Lbs	200 Lbs	400 Lbs
N524042RB	428 Lbs	1000 Lbs	500 Lbs	250 Lbs	500 Lbs
N524048RB	936 Lbs	1200 Lbs	800 Lbs	400 Lbs	700 Lbs

Nominal particle size removal rating is from 20-40 Micron
TDS, Application and flow rate will influence system performance.

FILTRATION MEDIA SELECTION GUIDE

Filter Ag®

Part Number A8014

Best for:

Sediment – Turbidity – Suspended Solids Removal

Filter Ag® is a silica crystalline quartz media that achieves superior filtration and higher solids loading compared to conventional filter media such as multi-layered or filter sand. Filter Ag provides a large irregular surface area and a complex flow path effectively trapping suspended solids and fine turbidity particles throughout the filter bed. The large and irregular shape allows deeper penetration into the bed for higher sediment loading and longer filter runs while preventing screening and caking of sediment in the top several inches of the bed.

Properties:

- NSF Standard 61 Listed
- Color – Light Gray to near white
- Dry bulk density 27-26 lbs/cu.ft.
- Mesh Size 12x30
- Uniformity Coefficient: 1.8
- Effective size – 0.67mm
- Surface Adsorption – Hydrophilic

Conditions for Operation:

- Service Flow – 3.5-5gpm/ft²
- Backwash Flow – 8-10gpm/ft²
- Backwash expansion– 20-40%
- Bed Depth – 24” to 36” Application Dependent

Advantages and Benefits:

- Cost effective replacement for sand, garnet and multi-media
- Lower pressure loss per ft² at given flow rate
- Higher solids loading reduces backwash frequency
- Good filtration performance at high flux rates
- Can be used in multi-layered applications with Chemsorb® or other media for difficult filtration problems

Performance:

Filtration (nominal) – 20-40 micron @ 5gpm/ft²

Filter Series	Media Volume CF	A7005A #20 Gravel	Lbs A7006A “D” Gravel	Tank Size	Service Flow Rate GPM			Backwash
					5gpm/sf	8gpm/sf	10gpm/sf	
BTF9	1	10	N/A	9” x 48”	2	3.5	4	4
BTF10	1-1/2	15	N/A	10” x 54”	3	5	6	5
BTF12	2	20	N/A	12” x 52”	4	6	8	7
BTF13	2-1/2	30	N/A	13 x 54”	5	7	10	9
BTF14	3	40	N/A	14” x 65”	6	9	12	10
BTF16	4	50	N/A	16 x 65”	7	11	14	14
BTF21	6	100	N/A	21” x 62”	13	19	26	24
BTF24	8	100	100	24” x 72”	16	25	32	30
BTF30	10	150	150	30” x 72”	25	39	50	50
BTF36	20	250	250	36” x 72”	35	59	70	70
BTF42	26	300	300	42” x 72”	48	77	96	95

FILTRATION MEDIA SELECTION GUIDE

Chemsorb®

Part Number A8015

Best for:

Sediment – Turbidity – Suspended Solids Removal

Chemsorb® is a natural eco-friendly granular zeolite (Clinoptilolite) media that achieves superior filtration and higher solids loading compared to conventional filter media such as multi-layered or filter sand. Chemsorb has surface micro-mineral projections with 0.25-10µm spacing that effectively trap suspended solids and fine turbidity particles. In addition the granules remove a wide range of colloidal and soluble, inorganic metallic contaminants by surface sorption, chemical binding, charge-neutralization, coagulation reactions and/or ionic ion exchange phenomena. The surface micro-projections, together with high surface area make it an ideal water filtration media.

Properties:

- NSF Standard 61 Listed
- Color – Gray/green to off white
- Dry bulk density 50 lbs/cu.ft.
- Mesh Size 14x40
- Uniformity Coefficient: 1.7
- Surface Area – average 29.9m²/g
- Surface Adsorption – Hydrophilic

Conditions for Operation:

- Service Flow – 12-20gpm/ft²
- Backwash Flow – 13-22gpm/ft²
- Backwash expansion– 40-50%
- Bed Depth – 30” to 48” Application Dependent

Advantages and Benefits:

- Cost effective replacement for sand, garnet and multi-media
- Lower pressure loss per ft² at given flow rate
- Higher solids loading reduces backwash frequency
- Superior filtration performance at high flux rates

Performance:

Filtration (nominal) – 3-5 micron @ 12gpm/ft²

Filter Series	Media Volume CF	A7005A #20 Gravel	Lbs A7006A “D” Gravel	Tank Size	Service Flow Rate GPM			Backwash
					8gpm/sf	12gpm/sf	15gpm/sf	
BTF9	1	10	N/A	9” x 48”	3.5	5	6.5	7
BTF10	1-1/2	15	N/A	10” x 54”	5	7	8	9
BTF12	2	20	N/A	12” x 52”	6	9	12	12
BTF13	2-1/2	30	N/A	13 x 54”	7	11	14	14
BTF14	3	40	N/A	14” x 65”	9	13	16	15
BTF16	4	50	N/A	16 x 65”	11	17	21	20
BTF21	6	100	N/A	21” x 62”	19	26	36	35
BTF24	8	100	100	24” x 72”	25	29	47	50
BTF30	10	150	150	30” x 72”	39	59	74	75
BTF36	20	250	250	36” x 72”	59	85	106	110
BTF42	26	300	300	42” x 72”	77	115	144	145

FILTRATION MEDIA SELECTION GUIDE

Birm®

Part Number A8006

Best for:

Iron – Manganese Removal

Birm® is an efficient and economical media for the reduction of dissolved Iron and Manganese compounds from raw water. Birm is a natural pumice mineral coated with manganese oxide. Birm acts as an insoluble catalyst to enhance the reaction between dissolved oxygen and Iron and Manganese compounds. The physical characteristics of Birm provide an excellent filter media which is easily cleaned by backwashing to remove the oxidized precipitant. Birm is not consumed in the oxidation process and therefore provides a tremendous economic advantage over other iron removal methods.

Properties:

- NSF Standard 61 Listed
- Color – Black
- Dry bulk density 40- 45lbs/ft³
- Mesh Size 10x40
- Uniformity Coefficient: 2.7
- Effective size 0.48mm

Advantages and Benefits:

- No Chemical regeneration is required
- Long mineral life with low attrition loss
- Only periodic backwash is required

Performance:

- Efficient removal to 10ppm dissolved Iron

Conditions for Operation:

- Service Flow – 3.5-5gpm/ft²
- Backwash Flow – 10-12gpm/ft²
- Backwash expansion– 20-40%
- Bed Depth – 30” to 36”
- pH range 6.8 – 9.0 pH should be 8.0 or higher for Manganese removal
- Alkalinity should be greater than 2 times the combined sulfate and chloride concentration
- Dissolved Oxygen (D.O.) content must be at minimum 15% of the Iron & Manganese content
- Free Chlorine concentration must be less than 0.5ppm
- Hydrogen Sulfide, Polyphosphates and oils must be removed prior to contact with Birm

Filter Series	Media Volume CF	A7005A #20 Gravel	Lbs A7006A "D" Gravel	Tank Size	Service Flow Rate GPM			Backwash
					3.5gpm/sf	5gpm/sf	8gpm/sf	
BTF9	1	10	N/A	9" x 48"	1.5	2	3.5	4
BTF10	1-1/2	15	N/A	10" x 54"	2	3	5	5
BTF12	2	20	N/A	12" x 52"	2.5	4	6	7
BTF13	2-1/2	30	N/A	13" x 54"	3	5	7	9
BTF14	3	40	N/A	14" x 65"	3.5	6	9	10
BTF16	4	50	N/A	16" x 65"	5	7	11	14
BTF21	6	100	N/A	21" x 62"	8	13	19	24
BTF24	8	100	100	24" x 72"	11	16	25	30
BTF30	10	150	150	30" x 72"	17	25	39	50
BTF36	20	250	250	36" x 72"	25	35	59	70
BTF42	26	300	300	42" x 72"	34	48	77	95

FILTRATION MEDIA SELECTION GUIDE

Catalox

Part Number A8015

Best for:

Iron – Manganese – Hydrogen Sulfide Removal

Catalox is a mined natural mineral form of manganese dioxide (MnO₂) used for removing hydrogen sulfide, iron and manganese compounds from water supplies. Catalox operates both as a classical filter working with an oxidant and as a catalytic media due to its ability to accelerate the reaction between the oxidizing agent and any prevalent dissolved oxygen with sulfide, iron and manganese present. Dissolved iron, manganese and hydrogen sulfide will stay in solution unless the equilibrium is changed. Iron and manganese that is not oxidized become catalytically precipitated and then adsorbed directly on the media. Catalox is a very dense media that stops oxidized (precipitated) forms of iron, manganese and hydrogen sulfide from passing through the bed. Most of the manganous manganese is rapidly removed in the first few inches of the media where it is further oxidized to manganese dioxide.

Properties:

- NSF Standard 61 Listed
- Color – Black
- Dry bulk density 125lbs/ft²
- Mesh Size 20x40
- Uniformity Coefficient: 1.77
- Effective size 0.51mm

Conditions for Operation:

- Service Flow –5-10gpm/ft²
- Backwash Flow –22-30gpm/ft²
- Backwash expansion– 15-30%
- Bed Depth – 24”-30”
- pH range 6.0 – 9.0

Advantages and Benefits:

- Performance is enhanced with Oxidants (Air, Chlorine or Potassium Permanganate)
- Long service life – 10 + years with low fines and attrition

Performance:

- Iron Removal -10ppm
- Manganese removal - 5ppm
- Hydrogen Sulfide removal – 3ppm

Filter Series	Media Volume CF	A7005A #20 Gravel	Lbs A7006A "D" Gravel	Tank Size	Service Flow Rate GPM			Backwash
					5gpm/sf	8gpm/sf	10gpm/sf	
BTF9	1	10	N/A	9" x 48"	2	3.5	4	7
BTF10	1-1/2	15	N/A	10" x 54"	3	5	6	9
BTF12	2	20	N/A	12" x 52"	4	6	8	12
BTF13	2-1/2	30	N/A	13 x 54"	5	7	10	14
BTF14	3	40	N/A	14" x 65"	6	9	12	15
BTF16	4	50	N/A	16 x 65"	7	11	14	20
BTF21	6	100	N/A	21" x 62"	13	19	26	35
BTF24	8	100	100	24" x 72"	16	25	32	50
BTF30	10	150	150	30" x 72"	25	39	50	75
BTF36	20	250	250	36" x 72"	35	59	70	110
BTF42	26	300	300	42" x 72"	48	77	96	145

FILTRATION MEDIA SELECTION GUIDE

Greensand Plus

Part Number A8045

Best for:

Iron – Manganese – Hydrogen Sulfide Removal

Greensand Plus™ is an efficient and economical media for the reduction of dissolved Iron, Manganese and Hydrogen Sulfide compounds from raw water. Greensand Plus is a natural silica sand core coated with manganese dioxide. The physical characteristics of Greensand Plus provide an excellent filter media which is easily cleaned by backwashing to remove the oxidized precipitant. Greensand Plus is not shipped in the regenerated form. Prior to use it is necessary to regenerate with a solution of Potassium Permanganate or Chlorine contacting the bed for a minimum of 4 hours. The regenerant level of 4 ounces per cubic foot is recommended.

Properties:

- NSF Standard 61 Listed
- Color – Black
- Dry bulk density 85lbs/ft³
- Mesh Size 18x60
- Uniformity Coefficient: 1.60
- Effective size 0.30-0.35mm

Conditions for Operation:

- Service Flow – 2-5gpm/ft²
- Backwash Flow – 12gpm/ft²
- Backwash expansion – 40%
- Bed Depth – 24”-30”
- pH range 6.2– 8.5

Advantages and Benefits:

- May be regenerated with Potassium Permanganate or Chlorine
- Continuous Regeneration (CR) or Intermittent Regeneration (IR)

Performance:

- Capacity for Iron alone – 600 grains per cubic foot
- Capacity for Iron and Manganese – 400 grains per cubic foot
- Capacity Hydrogen Sulfide – 175 grains per cubic foot
- Maximum Practical limit for Iron and/or Manganese – 15ppm
- Maximum Practical limit for Hydrogen Sulfide – 5ppm

Filter Series	Media Volume CF	A7005A #20 Gravel	Lbs A7003A .6-.8 Gravel	Tank Size	Service Flow Rate GPM			Backwash
					3.5gpm/sf	5gpm/sf	8gpm/sf	
BGS9	1	10	10	9" x 48"	1.5	2	3.5	4
BGS10	1-1/2	15	15	10" x 54"	2	3	5	5
BGS12	2	20	20	12" x 52"	2.5	4	6	7
BGS13	2-1/2	30	30	13" x 54"	3	5	7	9
BGS14	3	40	40	14" x 65"	3.5	6	9	10
BGS16	4	50	50	16" x 65"	5	7	11	14
BGS21	6	100	100	21" x 62"	8	13	19	24
BGS24	8	100	100	24" x 72"	11	16	25	30
BGS30	10	150	150	30" x 72"	17	25	39	50
BGS36	20	250	250	36" x 72"	25	35	59	70
BGS42	26	300	300	42" x 72"	34	48	77	95

FILTRATION MEDIA SELECTION GUIDE

Filtrisorb® F400 carbon

Part Number A9031C

Best for:

Taste & Odor Removal - Dechlorination

Filtrisorb 400 is a granular activated carbon developed for the removal of taste and odor compounds, disinfection by-products precursors, and other dissolved organic compounds from potable water supplies. Filtrisorb 400 can be used for groundwater applications but is specifically suitable for surface water supplies with higher levels of background total organic carbon.

As a high grade bituminous coal-based product, Filtrisorb 400 possesses the durability required in many water treatment applications and is capable of withstanding the abrasion and dynamics associated with hydraulic transport, backwashing and mechanical handling. The carbon is manufactured from superior grades of bituminous coal to maximize the distribution of lower energy adsorption pores in the carbon structure as measured by its iodine number while still maintaining a high trace capacity number for the adsorption of a broad range of high and low molecular weight organic contaminants.

Specific applications include:

- ◆Taste and Odor
- ◆Dechlorination

U. S. Sieve Series

Percent on 12 mesh.....5max

Percent through 40 mesh.....4max

Specifications:

Iodine Number, mg/g:1000min

Trace Capacity Number, mg/cc...10min

Abrasion Number75min

Total Ash, weigh%..... 7max

Apparent Density, g/cc.....0.52min

Water Soluble Ash, weight %.....9 Max.

Packaging: 55 Pound (25 kg) 2 cubic foot 5 Ply Bag

Complies with AWWA standard for GAC edition B604-05
ANSI/NSF Standard 61 and Food Chemicals Codex

Filter Series	Media Volume CF	A7005A #20 Gravel	Lbs A7003A .6-.8 Gravel	Lbs A7006A "D" Gravel	Tank Size	Service Flow Rate GPM			Backwash
						5gpm/sf	8gpm/sf	10gpm/sf	
BTF9	1	10	10	N/A	9" x 48"	2.2	3.5	4.4	5
BTF10	1-1/2	15	15	N/A	10" x 54"	2.8	4.4	5.5	7
BTF12	2	20	20	N/A	12" x 52"	4	6.3	8	9
BTF13	2-1/2	30	30	N/A	13 x 54"	4.6	7.4	9	10
BTF14	3	40	40	N/A	14" x 65"	5.4	8.6	11	12
BTF16	4	50	50	N/A	16 x 65"	7	11	14	14
BTF21	6	100	100	N/A	21" x 62"	12	19	24	24
BTF24	8	100	100	100	24" x 72"	16	25	31	30
BTF30	10	150	150	150	30" x 72"	25	39	49	50
BTF36	20	250	250	250	36" x 72"	35	57	71	70
BTF42	26	300	300	300	42" x 72"	48	77	96	95

Safety Message:

Wet activated carbon preferentially removes oxygen from air. In closed or partially closed containers and vessels, oxygen depletion may reach hazardous levels. If workers are to enter a vessel containing carbon, appropriate sampling and work procedures for potentially low oxygen spaces should be followed, including all applicable federal and state requirements.

FILTRATION MEDIA SELECTION GUIDE

Centaur® catalytic carbon

Part Number A8056

Best for:

Chloramines -Hydrogen Sulfide - Iron Removal

CENTAUR® 12x40 is a liquid phase virgin activated carbon that has been manufactured to develop catalytic functionality. The product is unique in that it concentrates reactants via adsorption and then promotes their reaction on the surface of the pores. CENTAUR 12x40 is produced from bituminous coal using a patented process. Although it is not impregnated with metals or alkali, it displays the catalytic functionality of these materials. This product is particularly suited for use in residential and commercial water filters, for treatment of process water in the bottling and soft drink industries, and for aquarium water treatment. CENTAUR 12x40 combines a fine pore structure for enhanced adsorption of trace contaminants with high catalytic activity for their elimination.

Specific applications include:

- ◆Removal of Chloramines
- ◆Removal of Iron
- ◆Removal of Hydrogen Sulfide

Specifications:

Peroxide No. *	14 max
Iodine No., mg/g	825 min
Ash, by weight %	7 max
Moisture, wt %, as packed	3 max
Abrasion No.	75 min
Apparent Density, g/ml	0.56 min

U.S. Sieve Series:

Percent on 12 mesh	5 max
Percent through 40 mesh	4 max

*Peroxide number utilizes the rate of decomposition of hydrogen peroxide by the carbon and is an indicator of the amount of catalytic activity.

Filter Series	Media Volume CF	A7005A #20 Gravel	Lbs A7006A "D" Gravel	Tank Size	Service Flow Rate GPM			Backwash
					Iron Removal	Hydrogen Sulfide	Chloramine	
BTF9	1	10	N/A	9" x 48"	2	3.5	2.5	4
BTF10	1-1/2	15	N/A	10" x 54"	3	5	3.5	5
BTF12	2	20	N/A	12" x 52"	4	6	5	7
BTF13	2-1/2	30	N/A	13 x 54"	5	7	6	9
BTF14	3	40	N/A	14" x 65"	6	9	7.5	10
BTF16	4	50	N/A	16 x 65"	7	11	10	14
BTF21	6	100	N/A	21" x 62"	13	19	16	24
BTF24	8	100	100	24" x 72"	16	25	20	30
BTF30	10	150	150	30" x 72"	25	39	30	50
BTF36	20	250	250	36" x 72"	35	59	60	70
BTF42	26	300	300	42" x 72"	48	77	75	95

Safety Message:

Wet activated carbon preferentially removes oxygen from air. In closed or partially closed containers and vessels, oxygen depletion may reach hazardous levels. If workers are to enter a vessel containing carbon, appropriate sampling and work procedures for potentially low oxygen spaces should be followed, including all applicable federal and state requirements.

FILTRATION MEDIA SELECTION GUIDE

Filtrisorb® F600 carbon

Part Number A9034C

Best for:

VOC – THM – MBTE – Pesticide - Organic Compound Removal

Filtrisorb 600 is a high grade granular activated carbon manufactured and optimized for superior performance in the removal of trace level organics from water. As a high grade bituminous coal based product Filtrisorb 600 possesses the durability required in many water treatment applications and is capable of withstanding the abrasion and dynamics associated with hydraulic transport, backwashing and mechanical handling. The carbon is manufactured from superior grades of bituminous coal to maximize the distribution of high energy adsorption pores in the carbon structure as measured by its Trace Capacity Number. This directly relates to the carbon's ability to adsorb organic contaminants at low concentrations.

Specific applications include:

- ◆Removal of MTBE (Methyl Tertiary-Butyl Ether)
- ◆Removal of DBCP (1,2-Dibromo-3-Chloropropane)
- ◆Removal of THMs (Trihalomethanes)
- ◆Removal of pesticides & herbicides
- ◆Removal of other organics at concentrations < 1 ppm
- ◆Potable water treatment
- ◆Groundwater treatment
- ◆Ultrapure water treatment

Specifications:

Iodine Number, mg/g: 850min
 Trace Capacity Number, mg/cc...16min
 Abrasion Number80min
 Total Ash, weigh%..... 7max
 Apparent Density, g/cc.....0.630min
 Water Soluble Ash, weight %.....7 Max.

U. S. Sieve Series

Percent on 12 mesh.....5max
 Percent through 40 mesh.....4max

Packaging: 55 Pound (25 kg) 2 cubic foot 5 Ply Bag

ANSI/NSF Standard 61 Certified

Filter Series	Media Volume CF	A7005A #20 Gravel	Lbs A7006A "D" Gravel	Tank Size	Service Flow Rate GPM			Backwash
					10 Min EBCT	7 Min EBCT	5 Min EBCT	
BTF9	1	10	N/A	9" x 48"	.75	1	1.5	4
BTF10	1-1/2	15	N/A	10" x 54"	1	1.5	2.25	5
BTF12	2	20	N/A	12" x 52"	1.5	2	3	7
BTF13	2-1/2	30	N/A	13 x 54"	1.75	2.5	3.75	9
BTF14	3	40	N/A	14" x 65"	2.25	3	4.5	10
BTF16	4	50	N/A	16 x 65"	3	4	6	14
BTF21	6	100	N/A	21" x 62"	4.5	6	9	24
BTF24	8	100	100	24" x 72"	6	8	12	30
BTF30	10	150	150	30" x 72"	7.5	10	15	50
BTF36	20	250	250	36" x 72"	15	20	30	70
BTF42	26	300	300	42" x 72"	19.5	26	39	95

Safety Message:

Wet activated carbon preferentially removes oxygen from air. In closed or partially closed containers and vessels, oxygen depletion may reach hazardous levels. If workers are to enter a vessel containing carbon, appropriate sampling and work procedures for potentially low oxygen spaces should be followed, including all applicable federal and state requirement.

SYSTEM DESIGN CONSIDERATIONS

Operation of the Softener

Hard water contains dissolved minerals in the form of Calcium (Ca) and Magnesium (Mg). Removal of these dissolved minerals is accomplished by ion exchange. As the raw water flows through the softener, sodium ions on the resin are exchanged for the dissolved mineral ions in the raw water producing softened process water. Once the ion exchange resin reaches its capacity, it must be regenerated with a brine solution to remove the accumulated minerals and continue the process.

Major Factors Affecting Performance

Iron and Manganese Content

Feedwater dissolved Iron & Manganese inlet levels should not exceed 1ppm. Higher levels will require removal by filtration to minimize irreversible resin fouling.

Chlorine Content

Maximum Free Chlorine is 0.1ppm. Higher levels will contribute to de-crosslinking of the resin matrix and loss of capacity. The presence of iron or heavy metals can have a catalytic effect and increase oxidative damage to the resin.

Total Dissolved Solids (TDS)

TDS levels in excess of 2,000ppm affect exchange capacity resulting in higher hardness leakage and incomplete regenerations.

Flow rates

Exceeding listed design flow rates will increase hardness leakage and may compromise resin structure integrity causing fractured and broken beads.

Operating Pressure

Feed pressure should be 40-100psi - Injectors will not function below 30psi.

Brine regeneration efficiency

Proper brine regeneration of the softener is the key element in the selected systems overall performance. Only high quality solar or pelletized salt should be utilized to assure brine injector system integrity and function, and provide optimal system capacity recovery. In calculating regeneration frequency and salt dosage consideration must be given to all potential factors influencing system operation and final water quality requirements. Continued system monitoring of inlet and outlet water quality will insure operational performance meets and or exceeds your customer's requirements.

Sizing and Selecting a Softener

Use compensated hardness when determining unit capacity. Use minimum unit softening capacity listed when selecting a softener. This allows the ability to increase system operation capacity by increasing salt dosage.

Time Clock (Automatic) or Metered (Demand) Initiated Regeneration

With time clock initiated regeneration, also referred to as Automatic, the control valve will regenerate the softener at a set fixed interval of days at 2:00 am. To ensure the softener does not run out of capacity due to high demand, an adequate reserve must be calculated and the estimated fixed interval reduced accordingly.

Metered initiated regeneration control valves, also referred to as demand initiated, count down the set capacity of the softener in gallons. A softener with a meter initiated control will only regenerate when required as determined by the volume of water softened. The meter initiated single tank regeneration is typically delayed until 2:00a.m., so an adequate reserve in gallons must be calculated to ensure the unit will provide soft water until the regeneration occurs. A twin tank alternating system regenerates immediately so regeneration water volume must be considered for calculating compensated hardness capacity. A meter initiated control saves both water and salt by regenerating the softener only when required whereas a time clock control which automatically regenerates regardless of usage.

Electromechanical or Electronic Control Timers

Electromechanical timers are clock initiated or meter initiated. They are relatively simple to operate and maintain. Regeneration cycles are typically fixed duration or adjusted by repositioning pins or with cam changes.

Electronic programmable timers offer time initiated, days of the week initiated or signal initiated regeneration. Regeneration cycles, regeneration type or time of day are touchpad adjustable. Regeneration overrides are available. The regeneration settings and volume remaining are settings remain stored during power outages.

Electronic systems provide greater efficiency with a variable reserve feature. The control does not require the installer to calculate a reserve; rather the valve continuously calculates the required reserve based on usage patterns. Electronic systems also maintain usage history as a diagnostic tool.

DEFINITIONS & FORMULAS

One Part per Million (PPM) – Measurement of one weight of dissolved substance per million weights of solution

One Milligram per Liter (Mg/L) – One Liter of water weighs one million milligrams so conversely One Milligram per Liter is equal to one part per million

One Grain per Gallon (GPG) equals 17.1 PPM or 17.1 Mg/l.

To convert Hardness to GPG - Divide hardness reported as PPM or Mg/l by 17.1 (Example: Hardness 130ppm \div 17.1 = 7.6gpg)

One Grain – A unit of weight equal to 1/7000th of a pound

Compensated Hardness takes into consideration minerals and other factors that will reduce unit capacity.

Calculating Compensated Hardness:

Multiply reported iron and/or manganese in PPM (or Mg/L) by 4 and add to gpg hardness. (Example: 8 gpg hardness + 1ppm Fe²⁺ x 4 =12gpg compensated hardness)

Calculating Cv:

Cv is the flow rate in gpm through a valve that causes a 1psi pressure drop. The Cv value is used to calculate pressure drops through valves at different flow rates. Cv Formula - Pressure drop (ΔP) = (gpm/Cv)² (Example: 25gpm flowing through a valve with a Cv value of 6.5, $\Delta P = (25/6.5)^2$ or $3.84^2 = 14.8$ psi)

Calculating Empty Bed Contact Time:

Empty Bed Contact Time (EBCT) is the residence time which process flow is in contact with the media.

EBCT Formula: Volume of media \div by Flow (in gpm \div 7.481) (Example: 5gpm flow rate in a 2 cubic foot filter, $5 \div 7.481 = .67$; 2 cubic feet \div .67 = 2.98 or 3 minutes EBCT)

One gallon of water will dissolve 3 pounds of salt.

Allow 1-1/2 hours for brine saturation for systems without grid plates.

Allow 4 hours for brine saturation for systems with grid plates.

SIZING GUIDE

Procedures and Estimating Guide

1 Obtain a water analysis:

- A. Analyze water on site with portable test kit.
- B. Contact the local water utility for their water analysis records.
- C. Draw a water sample and submit to a certified testing lab for analysis. (Recommended method)

2. Analysis should at minimum test for the following:

- A. Hardness as CaCO₃ in grains per gallon (gpg) or convert parts per million (ppm) to gpg by dividing ppm by 17.1
- B. Total Iron and Manganese in ppm or mg/l.
- C. Total Dissolved Solids (TDS) in ppm or mg/l.
- D. pH

3. Determine the daily water usage amount to be treated:

- A. Use consumption figures from water utility billings. (To convert billings in cubic feet to gallons multiply by 7.5)
- B. Take water meter readings.
- C. Use sizing tables on pages when Steps A or B are not available.

4. Determine continuous and peak flow rates:

- A. Use the Water Supply fixture Units (WSFU) from your State Plumbing Codes and Flow Rate Tables to determine required flow rate.
- B. Obtain flow rates for continuous equipment which requires softened water, such as boilers, reverse osmosis units...etc. from equipment specifications or manufacturer. (If flow rate data is given in pounds per hour, divide by 500 to convert to gallons per minute.)
- C. Install a digital readout water meter in gpm and record peak gpm during peak consumption.

5. Private water supplies:

- A. Determine the pumps capacity in continuous gpm.
- B. Check the pump start and stop settings.
- C. Install a pressure gauge if needed.

6. Determine daily water to be conditioned:

- A. All water conditioned.
- B. Hot water only.

7. Determine capacity required per day:

- A. Capacity = (Gallons Per Day x Grains Per Gallon) Add 3 grains per gallon for each ppm of ferrous clear water iron present. If ferrous iron content is above 2 ppm, consult factory for pretreatment that may be needed. If ferric iron is present, an iron filter is required.

8. Selecting the proper unit for capacity per day:

- A. To properly select the correct unit, go to the sizing and dimension guide and find the unit which will handle the peak daily capacity (grains per day) when regenerated on minimum salt dosages.
- B. Select a unit that will not regenerate any more often than every 2 - 3 days on low or medium salting.

SIZING GUIDE

C. Sizing systems on low or medium salting levels save up to 40% on annual salt costs plus additional water usage savings. Avoid sizing equipment which will require regeneration with the high salt dosage.

9. Analysis should at least test for the following

- A. When sizing for continuous flow rate, subtract the pressure drop at the operating gpm flow across the softener from line pressure. At least a 30 psi should be left for working pressure.
- B. When sizing for peak flow rate, subtract the pressure drop across the softener from line pressure. At least a 20 psi should be left for working pressure.

NOTE: Some automatic fixtures (such as Flushometer type toilets) have specific pressure requirements by the manufacturer which may be greater than 20 psi.

- C. If either (A) or (B) above is lower than the minimum allowable working pressure for the unit selected in Step # 8, select a larger softener which has a lower pressure drop at the gpm demand and capacity needed.
- D. Always conform to all local and state plumbing codes.

Other Important Checks

- 1. **Available Space** - Compare dimensions of unit(s) selected with the installation space provided.
- 2. **Doorways** - Make sure all equipment will fit through all doorways, hallways and elevators leading from the delivery area to installation site.
- 3. **Backwash Rates** - If unit is operated on a private water supply, make sure the pump will be able to maintain the backwash rate required. Drains on all installations must be able to handle the backwash flow rates of the unit(s) selected.
- 4. **Special Applications** - While most commercial equipment will produce satisfactory softened water at 1 to 2 grains hardness leakage for apartment buildings, hotels, laundries, and similar applications, some applications such as boiler, reverse osmosis etc. may require higher quality water of less than 3 - 5 ppm of hardness leakage. Consult BWS for these applications.

Maximum Allowable Flow Rate for Copper Tube Type M-ASTM B88*	
1"	21.0 gpm
1.25"	32.0 gpm
1.5"	46.0 gpm
2"	80.0 gpm
2.5"	120.0 gpm
3"	175.0 gpm
4"	280.0 gpm
*Velocities not to exceed 8 feet per second.	

Water Consumption Estimating Guide

This guide is provided for estimations only when actual meter readings are unavailable. Estimate peak gpm using "Supply Fixture Units" on page 6.

Apartments

- One Bedroom Units - 1.75 people/apt.
- Two Bedroom Units - 3 people/apt.
- Three Bedroom Units - 5 people/apt.
- Full Line - 60 G.P.D./person
- Hot Only - 25 G.P.D./person

Barber Shops

75 G.P.D./chair full line

Beauty Shops

300 G.P.D./station full line

Boilers

Steam boilers require 4.25 gallons of water per hour for each horsepower rating of the boiler. Many boilers have a condensate return and this percentage should be subtracted from the full demand to determine actual requirement.

SIZING GUIDE

Boilers (Cont'd)

The amount remaining is your "makeup" per hour.

The makeup water requires further softening.

Multiply the % of operation rating to determine actual makeup per hour. Multiply this number times hours of operation per day.

Example:

50 H.P. Boiler

60% Condensate Return

75% Operation Rating

24 Hours/Day

50 H.P. x 4.25 Gallons/Hour = 212.5 Gallons/Hour

212.5 Gallons x 60% Condensate - 127.5 Gallons/Hour

212.5 Gallons - 127.5 Condensate Return = 85 Gallons

Makeup

85 Gallons Makeup x 75%

Operating Rating = 65.25 Gallons Of Actual Makeup

65.25 Gallons x 24 Hours/Day = 1,566 Gallons/Day

If a boiler is rated in lbs/hour figure as follows:

10,000 lbs/500 = 20 G.P.D. less % return.

To Convert BTUs to HP multiply BTUs x .0003931

Boiler Feedwater (Makeup Requirements)

4.25 gallons/hour per Horsepower = Gallons of water evaporated/hour

Lbs. evaporation/hour x .12 = Gallons of water evaporated/hour

Feedwater makeup requirements:

1. Rated in horsepower - 4.25 gallons of water evaporated per hour. This is then multiplied by the percentage rating at which the boiler is operated. Example: A 300 HP boiler operated at 75% of rating = $300 \times 4.25 \times 75\% / 100\% = 956.25$ gallons of water evaporated/hour. Gallons per hour x hours/day = gallons/day of makeup.

2. Lbs. of evaporation/hour x 0.12 = Gallons of water evaporated per hour.

Example: $25,000 \text{ lbs.} \times 0.12 = 3000$ gallons of water evaporated/hour
Gallons/hour x hours/day = gallons per day of makeup.

Adjustment for Percentage of Condensate Returns:

If the boiler system doesn't use condensate return, then the feedwater makeup requirements above are used to determine sizing. When condensate returns are used, the feedwater makeup is the difference between the number of gallons of water evaporated per hour and the number of gallons of condensate return.

Example: 3600 gallons of water evaporated per hour and condensate return of 50%; the amount of boiler feedwater makeup required is: $3600 - (50\% \text{ of } 3600) = 1800$ gallons per hour of boiler operation for feedwater makeup. Gallons per hour x hours per day = gallons per day of makeup.

Bowling Alleys

75 G.P.D./Lane

Carwash

With the variety of number of different types of carwash systems available in today's market, we advise you to consult the specific manufacturer for your application.

G.P.M. Estimate:

1. Multiply the number of Self Serve Bays by 4.
2. Multiply the number of Automatic Bays by 38.
3. Add together the answers from step 1 and 2.
4. Add the Spot Free Rinse demand (from the manufacturer) to the total in step 3 to calculate the total G.P.M.

Consumption Guideline:

Average Gallons Per Day Automatic Bay - 6,840

Average Gallons Per Day Self Serve Bay - 600

Cooling Towers

To determine daily makeup in gallons:

1. Multiply the tonnage by 4. (This includes 2 gallons/hour/ton evaporation and 2 gallons/hour/ton/bleed off.)
2. Next multiply the answer in step 1 by the hours per day of operation.

Dormitories

40 G.P.D./Person Full Line

16 G.P.D./Person Hot Only

Factories

35 G.P.D./Person/Shift w/Showers Full Line

25 G.P.D./Person/Shift w/o Showers Full Line

NOTE: Estimate any process water separately.

Farm Animals

Dairy Cow - 35 G.P.D.

Beef Cow - 12 G.P.D.

Goat - 2 G.P.D.

Hog - 4 G.P.D.

Horse - 12 G.P.D.

Sheep - 2 G.P.D.

Chickens - 10 G.P.D./100 Birds

Turkeys - 18 G.P.D./100 Birds

Hospitals

250 G.P.D./Bed Full Line 170 G.P.D./Bed Hot Only

NOTE: Estimate air conditioning and laundry separately.

Laundry

1. Obtain capacity (Lbs) from customer or capacity table on next page.
2. Calculate usage and flow from formulas A & B.

Formula A = Capacity (Lbs) x 2.5 = Gallons/Cycle

Formula B = Capacity (Lbs) x 10% = Flow Rate (gpm)

SIZING GUIDE

Commercial Laundry Capacity Table

Tumbler Size (inches)	Clothes Capacity (lbs)	Tumbler Size (inches)	Clothes Capacity (lbs)	Tumbler Size (inches)	Clothes Capacity (lbs)	Tumbler Size (inches)	Clothes Capacity (lbs)
30 x 16	25	36 x 42	125	42 x 96	400	44 x 126	575
24 x 36	48	36 x 54	165	42 x 108	450	48 x 84	460
30 x 30	60	42 x 42	175	42 x 126	510	48 x 96	535
30 x 36	70	42 x 48	200	44 x 54	245	48 x 120	680
30 x 42	80	42 x 54	225	44 x 64	300	48 x 126	715
30 x 48	95	42 x 64	265	44 x 72	330	54 x 84	600
36 x 30	90	42 x 72	300	44 x 84	385	54 x 96	680
36 x 36	110	42 x 84	350	44 x 96	440	60 x 96	900

MOTEL

100 G.P.D./Room Full Line
40 G.P.D./Room Hot Only

NOTE: Estimate the restaurant, bar, air conditioning, swimming pool, and laundry facilities separately and add to room total.

MOBILE HOME COURT

Estimate 3.75 People/Home
60 G.P.D./Person

NOTE: Estimate outside water for sprinkling, washing cars, etc. separately.

NURSING HOMES

75 G.P.D./Bed Full Line
50G.P.D./Bed Hot Only

NOTE: Estimate laundry separately

OFFICE BUILDING

15 G.P.D./Person Full Line

2 G.P.D./Person Hot Only

RESTAURANTS

10 G.P.D./Person Full Line
4 G.P.D./Person Hot Only
2 G.P.D./Person Cocktail Bar Facilities

REST HOMES

175 G.P.D./Bed Full Line
100 G.P.D./Bed Hot Only
NOTE: Estimate laundry separately

SCHOOLS

20 G.P.D./Student Full Line w>Showers
10 G.P.D./Student Full Line w/o Showers
10 G.P.D./Student Hot Only w>Showers
4 G.P.D./Student Hot Only w/o Showers

TRAILER PARKS

100 G.P.D./Space

FLOW RATE ESTIMATING CHART IN U.S. GALLONS

Instructions For Use:

1. Count and total the number of each type of fixture to be serviced by water conditioning equipment.
2. Multiply the number of each type of fixture by the unit count given for the appropriate water supply fixture table.
Private - Apartment Buildings, Trailer Parks, Group Homes, Houses, etc.
Public - Office Buildings, Hospitals, Motels, Clubs, Schools, etc.
NOTE: Make sure you use the correct values for hot, cold or hot & cold.
3. Find the total fixture count by adding the values found in Step 2.
4. Using the correct chart on page 6, find your total supply fixture count value in the left hand column and read across to the right to find the gpm demand. Make sure you use the correct gpm column for "private" or "public".

Example: 10 Unit Apartment (Hot Only)

10 Kitchen Sinks @ 1	= 10
10 Dishwashers @ 1	= 10
10 Bathroom Groups @ 2	= 10
10 Automatic Clothes Washers @ 1	= 10
Total SFUs	= 50
GPM Demand	= 28

When both private and public fixtures are present, use the "predominately" higher percentage of private or public to obtain your gpm demand.

SIZING GUIDE

WATER SUPPLY FIXTURE UNITS FOR PUBLIC USE FIXTURES

TYPE OF FIXTURE ^a	WATER SUPPLY FIXTURE UNITS		
	(WSFU)		
	Hot	Cold	Total
Automatic Clothes Washer, Individual	2.0	2.0	3.0
Automatic Clothes Washer, Large Capacity	b	b	b
Bathtub, with or without Shower Head	2.0	2.0	3.0
Coffeemaker		0.5	0.5
Dishwasher, Commercial	b	b	b
Drink Dispenser		0.5	0.5
Drinking Fountain		0.25	0.25
Glass Filler		0.5	0.5
Hose Bibb: 1/2" diameter		3.0	3.0
3/4" diameter		4.0	4.0
Icemaker		0.5	0.5
Lavatory	0.5	0.5	1.0
Shower, per Head	2.0	2.0	3.0
Sinks: Bar and Fountain	1.5	1.5	2.0
Barber and Shampoo	1.5	1.5	2.0
Cup		0.5	0.5
Flushing Rim		7.0	7.0
Kitchen and Food Preparation per faucet	2.0	2.0	3.0
Laboratory	1.0	1.0	1.5
Medical Exam and Treatment	1.0	1.0	1.5
Service	2.0	2.0	3.0
Surgeon Washup	1.5	1.5	2.0
Urinal: Siphon Jet		4.0	4.0
Washdown		2.0	2.0
Wall Hydrant, Hot and Cold Mix: 1/2" diameter	2.0	2.0	3.0
3/4" diameter	3.0	3.0	4.0
Wash Fountain: Semicircular	1.5	1.5	2.0
Circular	2.0	2.0	3.0
Water Closet: Flushometer		7.0	7.0
Gravity Type Flush Tank		3.0	3.0

WATER SUPPLY FIXTURE UNITS FOR PUBLIC USE FIXTURES

TYPE OF FIXTURE ^a	WATER SUPPLY FIXTURE UNITS		
	(WSFU)		
	Hot	Cold	Total
Automatic Clothes Washer	1.0	1.0	1.5
Bar Sink	0.5	0.5	1.0
Bathtub, with or without Shower Head	1.5	1.5	2.0
Bidet	1.0	1.0	1.5
Dishwasher Machine		1.0	1.0
Glass Filler		0.5	0.5
Hose Bibb: 1/2" diameter		3.0	3.0
3/4" diameter		4.0	4.0
Kitchen Sink	1.0	1.0	1.5
Laundry Tray, 1 or 2 Compartment	1.0	1.0	1.0
Lavatory	0.5	0.5	1.0
Shower, per Head	1.0	1.0	1.5
Water Closet: Flushometer		6.0	6.0
Gravity Type Flush Tank		2.0	2.0
Bathroom Groups:			
Bathtub, Lavatory and Water Closet - Flushometer	2.0	4.5	8.0
Bathtub, Lavatory and Water closet - Flush Tank	2.0	3.5	4.0
Shower Stall, Lavatory and Water Closet - Flushometer	1.5	7.0	7.5
Shower Stall, Lavatory and Water closet - Flush Tank	1.5	3.0	3.5

Note a: For fixtures not listed, factors may be assumed by comparing the fixture to a listed fixture which uses water in similar quantities and at similar rates.

Note b: Load factors in gallons per minute, gpm, based on manufacturer's requirements.

Source: Wisconsin Administrative Code, Register, October, 1991, No. 430, 428

-sizing guide

CONVERSION OF WATER SUPPLY FIXTURE UNITS TO GALLONS PER MINUTES

Water Supply Fixture Units	GALLONS PER MINUTE	
	<i>Predominately Flushometer Type Water Closets or Siphon Jet Urinals</i>	<i>Predominately Flush Tank Type Water Closets or Washdown Urinals</i>
1	-	1
2	-	2
3	-	3
4	10	4
5	15	4.5
6	18	5
7	21	6
8	24	6.5
9	26	7
10	27	8
20	35	14
30	40	20
40	46	24
50	51	28
60	54	32
70	58	35
80	62	38
90	65	41
100	68	42
120	73	48
140	78	53
160	83	57
180	87	61
200	92	65
250	101	75
300	110	85
400	126	105
500	142	125
600	157	143
700	170	161
800	183	178
900	197	195
1000	208	208
1250	240	240
1500	267	267
1750	294	294
2000	321	321
2250	348	348
2500	375	375
2750	402	402
3000	432	432
4000	525	525
5000	593	593

NOTE: Values not specified in the table may be calculated by interpolation.

Source: Wisconsin Administrative Code, Register, October, 1991, No. 430

SIZING GUIDE

Worksheet

Sizing for BWS Commercial Units

Prospect Name: _____ Date: _____

Address: _____

Contact Person: _____ Telephone: _____

Prepared By: _____

A. Water to be Used for (Circle Your Response)

School Laundry	Restaurant Dishwasher	Motel Other _____	Boiler RO
-------------------	--------------------------	----------------------	--------------

B. Hours per day operation _____ Days per Week _____

C. Water requirements

(a) Constant flow rate _____ gpm Peak flow _____ gpm

(b) Daily usage/24 hour _____ gal Days per week - 5, 6, 7 _____ ?

(c) Was usage determined by fixture count? flow meter? water bill?

D. Water quality required

Permissible hardness leakage _____ ppm?

E. Water, Influent (Circle Your Response)

(a) Source: Municipal Private Well Both

(b) Composition:

Total Hardness _____ gpg	Color _____
Ca + Mg _____	Turbidity _____
Iron _____ ppm	Other _____
pH _____	
H ₂ S _____ ppm	T.D.S. _____

F. Facilities

Supply pipe size _____ inches Operating pressure _____ to _____ psi

Pump capacity _____ gpm Pressure at point of installation _____ psi

Drain line sump _____ Minimum pressure allowed after unit _____ psi

G. Installation details or limitations

Available floor space _____ " length x _____ " width x _____ " height

What floor _____ Weight versus floor support _____

H. Installation details or limitations

Door openings _____ Stairways _____

Remote brine tank location _____

Any other unusual installation requirements _____

I. Existing equipment at this prospect?

Tank size _____ " diameter x _____ " height

Valve size _____ Capacity _____ cu. ft. Resin _____

Make _____ Model # _____ Approx. age _____

J. Notes:

SYSTEM CONFIGURATION OPTIONS

System 4

Single System , 1 Valve, Time clock - Meter Delayed or Immediate

Time Clock – The control regenerates on the days selected at the regeneration time selected

Meter Delayed – The control regenerates at the regeneration time selected after the volume of treated water drops to less than the reserve capacity or the volume drops to 0.

Meter Immediate – The control regenerates immediately once the volume set drops to 0.

System 5

Interlocked System, 2 – 4 Valves, Meter Immediate

Meter on each valve

Each with No Hardwater Bypass Piston

Capacity - Individual

All in Service at the same time, except during regeneration

Adds each programmed meter volume for system volume, once the cumulative capacity reaches zero the units regenerate sequentially.

System 6

Series Regeneration, 2 – 4 Valves, Meter Immediate or Delayed

1 Remote Meter

Each with No Bypass Piston

Capacity – Total

All units are in Service, except during regeneration. Once the set capacity reaches zero the units regenerate sequentially.

System 7

Alternating System, 2 Valves, Meter Immediate

1 Remote meter

Each with No Bypass Piston

Capacity – Individual

1 in Service and 1 in Standby (off line). When the meter zeros out or days override feature is activated the Standby will come on line to Service and the Service unit will go to Standby and regenerate.

System 9

Alternating System, 2 – 4 Valves Meter Immediate

Meter on each valve

Each with No Bypass Piston

Capacity – Individual

Always 1 in Standby (off line) during regeneration the Standby will come to Service and one of the service units will go to Standby and regenerate.

System 14

Alternating System, 2 – 4 Valves, Meter Immediate

Meter on each valve

Each with No Bypass Piston

Capacity – Individual

Always 1 unit in service and others are in standby or regeneration. As flow increases to preset volume (and after preset duration) the standby unit(s) will ramp up into service as needed. As flow rate decreases units will ramp down back to standby mode. When regeneration is required for the service unit a standby unit goes to service and the exhausted softener regenerates and goes to standby.

RESIN CAPACITY

RESIN VOLUME CUBIC FEET	RESIN CAPACITY SETTING AT			
	6 POUNDS FT 3	8 POUNDS FT 3	10 POUNDS FT 3	15 POUNDS FT 3
1.0	20,000	24,000	27,000	30,000
1.5	30,000	36,000	40,500	45,000
2.0	40,000	48,000	54,000	60,000
2.5	50,000	60,000	67,500	75,000
3.0	60,000	72,000	81,000	90,000
4.0	80,000	96,000	108,000	120,000
5.0	100,000	120,000	135,000	150,000
6.0	120,000	144,000	162,000	180,000
7.0	140,000	168,000	189,000	210,000
8.0	160,000	192,000	216,000	240,000
9.0	180,000	216,000	243,000	270,000
10.0	200,000	240,000	270,000	300,000
12.0	240,000	288,000	324,000	360,000
15.0	300,000	360,000	405,000	450,000
20.0	400,000	480,000	540,000	600,000
25.0	500,000	600,000	675,000	750,000
30.0	600,000	720,000	810,000	900,000
35.0	700,000	840,000	945,000	1,050,000
40.0	800,000	960,000	1,080,000	1,200,000
45.0	900,000	1,080,000	1,215,000	1,350,000
50.0	1,000,000	1,200,000	1,350,000	1,500,000
55.0	1,100,000	1,320,000	1,485,000	1,650,000
60.0	1,200,000	1,440,000	1,620,000	1,800,000
70.0	1,400,000	1,680,000	1,890,000	2,100,000

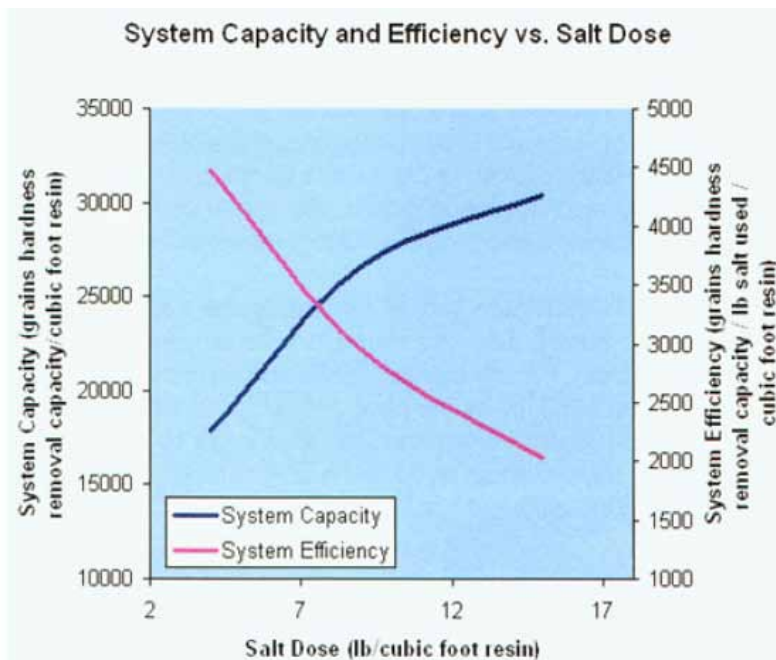

The capacity of a softener will increase as the salt dose increases; however, brine efficiency *decreases* as the salt dose is increased because less capacity is gained for each additional pound of salt used. For example, 4 pounds of salt gives a capacity of 17,900 grains. Increasing the salt dose to 9 pounds of salt increases the salt used by a factor of 2.25, while capacity only increases to 26,600 grains, an increase of 1.5 times.

Brine efficiency is higher at a lower salt dose (more hardness is removed per pound of salt used to regenerate the system); therefore, the system can be run more efficiently by lowering the salt dose. There are practical limits to the minimum salt dosage depending on water characteristics and treated water quality requirements. Theoretically, the maximum efficiency for a softener is around 6000 grains/lb salt. Practically, systems are rarely set up with a salt dose of much less than 3 lb/ft³, and peak efficiencies rarely exceed 5100 gains/lb.

SIZING TABLES

TANK DIAMETER INCHES	TANK DIAMETER SQUARE FT. BED AREA	CU. FT. PER INCH OF HEIGHT	BACKWASH RATE IN GPM PER SQUARE FOOT OF BED AREA AT:					
			5 GPM	8 GPM	10 GPM	12 GPM	15 GPM	30 GPM
6	0.196	0.016	1.0	1.6	2.0	2.4	2.9	5.9
7	0.267	0.022	1.3	2.1	2.7	3.2	4.0	8.0
8	0.35	0.029	1.8	2.8	3.5	4.2	5.3	10.5
9	0.44	0.036	2.2	3.5	4.4	5.3	6.6	13.2
10	0.55	0.042	2.8	4.4	5.5	6.6	8.3	16.5
12	0.79	0.066	4.0	6.3	7.9	9.5	11.9	23.7
13	0.92	0.077	4.6	7.4	9.2	11.0	13.8	27.6
14	1.07	0.089	5.4	8.6	10.7	12.8	16.1	32.1
16	1.4	0.117	7.0	11.2	14.0	16.8	21	42
21	2.4	0.2	12	19.2	24.0	28.8	36	72
22	2.64	0.22	13.2	21.1	26.4	31.7	39.6	79.2
24	3.14	0.262	15.7	25.1	31.4	37.7	47.1	94.2
30	4.9	0.408	24.5	39.2	49.0	58.8	73.5	147
36	7.07	0.589	35.4	56.6	70.7	84.8	106.1	212.1
42	9.62	0.802	48.1	77.0	96.2	115.4	144.3	288.6
48	12.57	1.048	62.9	100.6	125.7	150.8	188.6	377.1
54	15.9	1.325	79.5	127.2	159.0	190.8	238.5	477
60	19.63	1.636	98.2	157.0	196.3	235.6	294.5	588.9
66	23.76	1.98	118.8	190.1	237.6	285.1	356.4	712.8
72	28.27	2.356	141.4	226.2	282.7	339.2	424.1	848.1

USEFUL FORMULAS

MEDIA HEIGHT IN INCHES = CUBIC FEET OF MEDIA DIVIDED BY CU.FT. PER INCH OF HEIGHT

Example: 14" tank and 3cf of media
 $3(\text{cf}) \div 0.089 = 33.7"$ media height

ACTUAL BACKWASH FLOW RATE = REQUIRED RATE TIMES TANK DIA. SQ. FT. BED AREA

Example: 12" tank with a media requiring 12gpm/sf Backwash rate
 $12(\text{gpm}) \times 0.79 = 9.5 \text{ gpm}$ actual flow to equal 12gpm in that tank

MEDIA	POUNDS PER CF	SERVICE FLOW GPM/SQ. FT.	BACKWASH RATE GPM/SQ. FT.	BED DEPTH INCHES	BED EXPANSION
BIRM	45	3.5 - 5	10 - 12	30 - 36	20 - 40%
CARBON ¹	31	3	10 - 12	26 - 30	30 - 40%
CARBON ²	31	10	10 - 12	26 - 30	30 - 40%
CATALOX	125	5 - 10	22 - 30	30 - 36	15 - 30%
CALCITE	100	3 - 6	8 - 12	24 - 30	35%
COROSEX	75	3 - 6	8 - 12	24 - 30	50%
FILTER AG	26	5	8 - 10	24 - 36	20 - 40%
GREENSAND	85	5	10 - 12	30	40%
RESIN (STD)	52	20 - 30	3 - 8	30	50 - 75%
RESIN (FINE)	52	15 - 20	2.5 - 4	30	50 - 75%
KDF	177	15	30	10	10 - 15%

¹ Service flow based on organics removal

² Service flow based on dechlorination

TERMS AND CONDITIONS

Minimum Orders

Minimum order is \$50 per shipment.

Payment Terms, Domestic Customers

Payments are due within thirty (30) days from the date of invoice with prior credit approval. Otherwise, payments are due prior to shipment by check, funds transfer, or credit card. COD shipments are to be paid by certified, cashier's, or company check with credit references provided.

Payment Terms, International Customers

Payments are due in U.S. dollars by advance payment, funds transfer, check, or credit card, covering merchandise and any prepaid freight charges that may apply.

Irrevocable letters of credit are accepted with a minimum order of \$20,000 in U.S. dollars, per order. Letters of credit must be in favor of Blake Water Solutions; stipulate payment is based on sight of shipping papers; state all charges to be applied to buyer's account, and specify F.O.B. point is ex-factory. (Additional banking and processing fees will be charged.)

Shipment

All shipments are F.O.B. distribution centers, located in the United States.

Transportation

Claims for goods damaged in shipment or shortages must be made by customer directly with freight carrier.

Returns

All returns must be approved by Blake Water Solutions, and a Returns Goods Authorization (RGA) must be issued. A twenty-five (25) percent restocking charge may apply to authorized returns. Once an RGA is issued, merchandise is to be returned to Blake Water Solutions, freight prepaid. (Please see Returns Goods Policy for more details.)

Verbal Orders

We ask our customers to place all orders in writing. Verbal orders (and verbal changes to orders) will be accepted only with the understanding that Blake Water Solutions is not responsible to cover freight charges for returned merchandise placed by verbal order. Furthermore, all merchandise returned for credit placed on a verbal purchase order is subject to a twenty-five (25) percent restocking charge, unless confirmation has been received during office hours, prior to shipment.

Limited Warranty

Most Blake Water Solutions products come with a limited warranty covering materials and workmanship. Some products sold by Blake Water Solutions have no warranty, or they are covered by the original manufacturer's warranty. Please contact Blake Water Solutions and refer to Limited Warranty information for more details.

Deposit / Partial Payment for Custom Products and Products Made-to-Order

Custom products, including all package filtration systems, custom reverse osmosis equipment, industrial filter housings made to AMSE design specifications and other products made-to-order require a deposit before the order can be accepted. (Please contact our customer service department for a copy of our deposit schedule.) Furthermore, this equipment cannot be returned under any circumstances.

Prices

We make every effort to notify customers with price change information. However, prices are subject to change without notice.

Past Due Accounts

A 1.5% per month service charge will be applied to all accounts past due thirty (30) days or more.

Policy

The terms and conditions described above supersede any previously written terms and conditions that appear in company documents. Any changes to our terms and conditions must be authorized by Blake Water Solutions.

RETURN GOODS POLICY

1. Customers are to provide the following information:
 1. Contact name
 2. Company name
 3. Customer number
 4. Products to be returned and reason for the return
 5. Customer's P.O. number under which the goods were purchased (if issued)
 6. Blake Water Solutions' invoice number under which the goods were purchased
2. Requests for returns must be approved by the Return Goods Administrator, and only the RGA Administrator shall issue Return Goods Authorizations.
3. No products may be returned, nor shall credits be processed until written approval has been issued by the Blake Water Solutions RGA Administrator.
4. Transportation costs and risk of damage or loss in transit are the customer's responsibility.
5. Goods returned for credit or refund, including goods returned for inspection under warranty, must be shipped to the warehouse by prepaid transportation. No "collect" shipments will be accepted.
6. Customers should not return merchandise unless a Return Goods Authorization has been issued. Please note RGA numbers on the shipping label for proper processing, and include a copy of the RGA form inside the shipping carton for prompt attention.
7. Products not currently offered for sale as standard will not be accepted for credit.
8. Only salable goods may be returned.
9. Custom products, such as backwashing filters, filtration systems, and commercial softeners, may not be returned.
10. Commercial and residential RO systems that have been installed may not be returned under any circumstances.
11. Authorized credits will be issued at the price paid, less a twenty-five (25) percent restocking charge plus repackaging costs (if necessary).

Important

If customers claim returns are due to company error, the burden of proof is the customer's responsibility. If the matter cannot be resolved by telephone, customer may elect to return merchandise by prepaid freight for inspection, so the matter may be further investigated.

If the company agrees we are in error, return freight costs will be credited or refunded to the customer.



The Blake Group is a growing family of companies dedicated to providing our valued customers with superior products and technologies in commercial, industrial, and residential markets, compliant with industry standards and meeting all facets of our customers' expectations.



CONNECTICUT

*Corporate Office
& Manufacturing*

**THE BLAKE GROUP
EAST WINDSOR**

4 New Park Road
East Windsor, CT 06088
Phone: (800) 353-1100

Sales & Distribution

**BLAKE EQUIPMENT
SOUTH WINDSOR**

41 Commerce Way
South Windsor, CT 06074
Phone: (800) 593-7867

**BLAKE EQUIPMENT
DANBURY**

34 Executive Drive
Danbury, CT 06810
Phone: (800) 791-7867

NEW HAMPSHIRE

Sales & Distribution

**BLAKE EQUIPMENT
ALTON**

166 Wolfeboro Hwy.
Alton, NH 03809
Phone: (800) 552-0389

Sales & Service

**NORTHEAST MECHANICAL
HOOKSETT**

198 Londonderry Tpke.
Hooksett, NH 03106
Phone: (603) 624-1507

NEW YORK

Sales & Distribution

**BLAKE EQUIPMENT
ALBANY**

13 Thatcher Street
Albany, NY 12207
Phone: (518) 465-0713

**BLAKE EQUIPMENT
EAST SYRACUSE**

6059 Corporate Drive
East Syracuse, NY 13057
Phone: (800) 792-2346

**BLAKE EQUIPMENT
ONEONTA**

Route 23 Southside
Oneonta, NY 13820
Phone: (800) 336-6611

**BLAKE EQUIPMENT
PINE ISLAND**

76 Skinner Lane
Pine Island, NY 10969
Phone: (800) 914-0099

Sales & Service

**JW STEVENS
ALBANY**

11 Thatcher Street
Albany, NY 12207
Phone: (518) 482-8833

**JW STEVENS
EAST SYRACUSE**

6059 Corporate Drive
East Syracuse, NY 13057
Phone: (315) 472-6311

MAINE

Sales & Distribution

**BLAKE EQUIPMENT
HERMON**

1194 Odlin Road
Hermon, ME 04401
Phone: (800) 450-6822

**BLAKE EQUIPMENT
PORTLAND**

470 Riverside Street
Portland, ME 04103
Phone: (800) 308-2213

Sales & Service

**NORTHEAST MECHANICAL
HERMON**

1194 Odlin Road
Hermon, ME 04401
Phone: (207) 989-2256

**NORTHEAST MECHANICAL
PORTLAND**

470 Riverside Street
Portland, ME 04103
Phone: (207) 400-8300

MASSACHUSETTS

Sales & Distribution

**BLAKE EQUIPMENT
GREENFIELD**

28 Butternut Street
Greenfield, MA 01301
Phone: (800) 628-1998

RHODE ISLAND

Sales & Distribution

**BLAKE EQUIPMENT
PASCOAG**

222 Davis Drive
Greenfield, MA 02859
Phone: (800) 869-7677

VERMONT

Sales & Distribution

**BLAKE EQUIPMENT
RUTLAND**

157 Quality Lane
Rutland, VT 05701
Phone: (800) 643-7100



Blake Water Solutions | Blake Equipment | JW Stevens | Northeast Mechanical

The Blake Group • 4 New Park Road • East Windsor, CT 06088

(800) 353-1100 • www.blakeequip.com